

GALISTEO WATERSHED CONSERVATION INITIATIVE

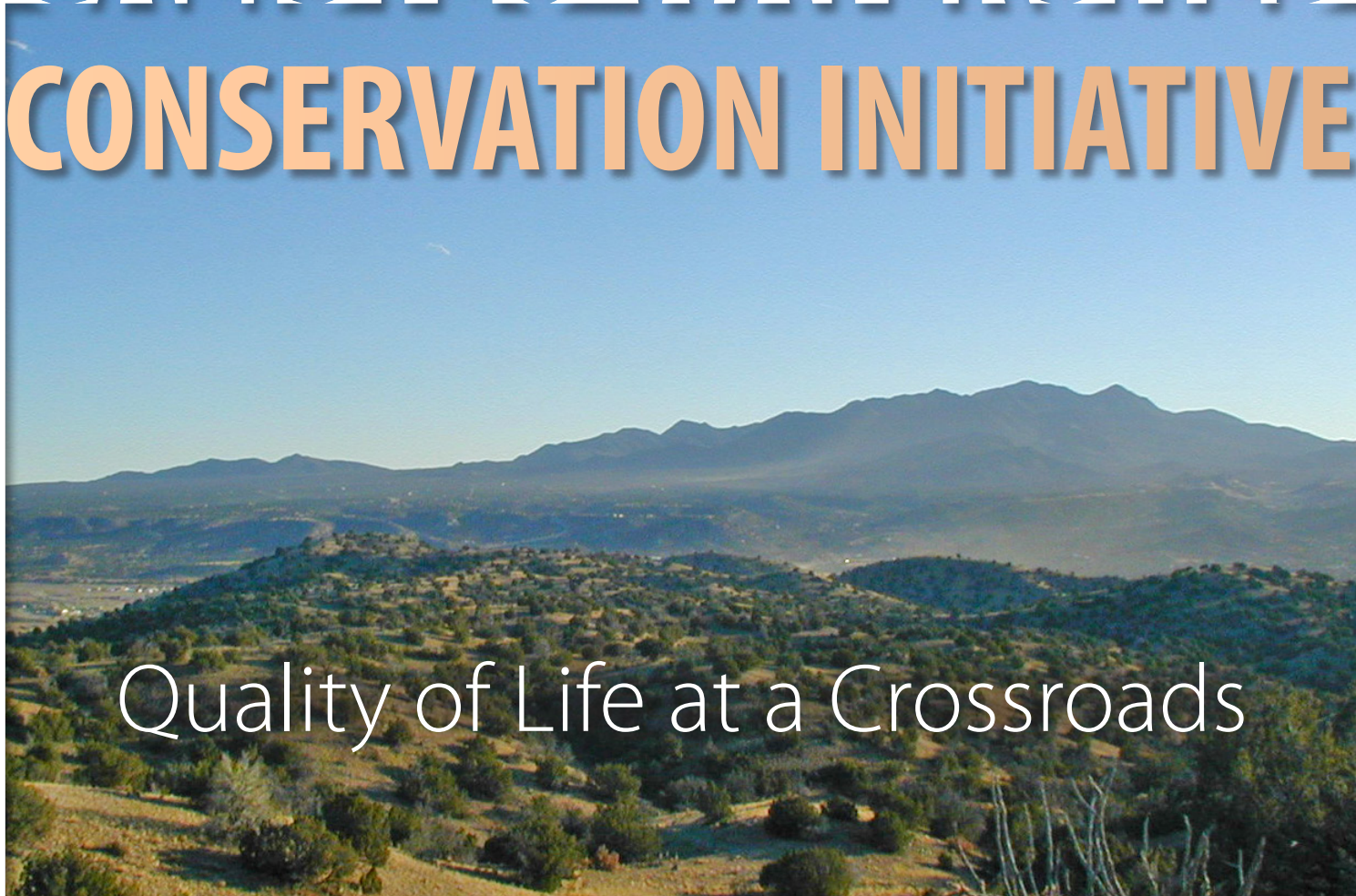

Quality of Life at a Crossroads

BY EARTH WORKS INSTITUTE & SANTA FE CONSERVATION TRUST
IN PARTNERSHIP WITH EARTH ANALYTIC, INC.
AUGUST 2011

CONTENTS

ACKNOWLEDGMENTS	I
EXECUTIVE SUMMARY	II
INTRODUCTION	1
1.1 PARTNERS AND HISTORY	3
1.2 INITIATIVE PURPOSE AND NEED	5
1.3 INITIATIVE OBJECTIVES	10
1.4 INITIATIVE RESULTS, PRODUCTS, AND INTENDED USERS	11
1.5 INITIATIVE AREA DESCRIPTION	12
METHODS	16
2.1 GREEN INFRASTRUCTURE PLAN FOR THE GALISTEO WATERSHED	17
2.2 CONSERVATION AND RESTORATION PILOT PROJECT	25
RESULTS	30
3.1 GREEN INFRASTRUCTURE PLAN FOR THE GALISTEO WATERSHED	31
3.2 CONSERVATION AND RESTORATION PILOT PROJECT	62
RECOMMENDATIONS	68
4.1 GREEN INFRASTRUCTURE PLAN FOR THE GALISTEO WATERSHED	69
APPENDICES	82
APPENDIX A: TERMS AND ACRONYMS	83
APPENDIX B: REFERENCES	87
APPENDIX C: STEERING COMMITTEE MEMBERS, AFFILIATIONS, AND CONTACT INFORMATION	89
APPENDIX D: DETAILED METHODS	91
APPENDIX E: GIS METHODS AND RESULTS	95
APPENDIX F: EXPERT INPUT PROCESS	137
APPENDIX G: LIST OF CONSERVATION ORGANIZATIONS	150
APPENDIX H: ABOUT SANTA FE CONSERVATION TRUST AND EARTH WORKS INSTITUTE	151
APPENDIX I: GALISTEO SPECIES—BIOTA INFORMATION SYSTEM	153
APPENDIX J: RECOMMENDED CONSERVATION RESTORATION PRIORITIES	156
APPENDIX K: SIGNIFICANT CONSERVATION VALUE (SCV) MODEL MAPS	160

ACKNOWLEDGMENTS

The Galisteo Watershed Conservation Initiative (GWCI) team thanks the Office of the State Engineer/Interstate Stream Commission, the County of Santa Fe, the University of New Mexico's Community & Regional Planning Program, and the National Park Service's Rivers, Trails & Conservation Assistance Program for their guidance over the course of this Initiative.

SUPPORT FOR THE GWC INITIATIVE

Funds for the GWCI were provided by the State of New Mexico as administered by the New Mexico Office of the State Engineer (OSE), Interstate Stream Commission (ISC). The partners wish to thank the visionary support of former State Representative Max Coll and State Senator Phil Griego, co-sponsors of the bills that enabled the funding and establishment of the GWCI.

Advisory support and material aid have been provided by the Santa Fe County Planning Division and the OSE/ISC. Our thanks go to County Planner Beth Mills, ISC staff Tim Murrell and Gar Clarke, former Trust employees Melisa Collett and Cyrus Samii, and GWCI Steering Committee members Alan Ragins (National Park Service) and David Henkel (UNM School of Architecture and Planning). Tom Seamster provided expert editing assistance, for which we are most grateful. Additionally, we wish to thank the local and professional experts who provided feedback during a series of expert meetings in the spring and summer of 2006. Finally, we thank Commonwealth Conservancy for graciously supporting us in the implementation of this Initiative's Conservation and Restoration Pilot Project on the Galisteo Basin Preserve.

THE AUTHORS

This document was written by Jan-Willem Jansens, Executive Director of Earth Works Institute; Rici Peterson, former Executive Director of Santa Fe Conservation Trust; and Wetherbee Dorshow, President of Earth Analytic. The authors received editorial support from Charlie O'Leary (current Executive Director of Santa Fe Conservation Trust) and Tom Seamster. Thanks to Erfert Fenton and Claudia McCue, whose editorial and production skills were invaluable in producing printed and online versions of this document.

Except where noted, all photographs are courtesy of Earth Works Institute.

To contact the authors, please use the following e-mail addresses:

Jan-Willem Jansens: jwj@earthworksinstitute.org

Rici Peterson: ricipeterson@gmail.com

Wetherbee Dorshow: wdorshow@earthanalytic.com

EXECUTIVE SUMMARY

The Galisteo Watershed: Landscape at a Crossroads. The Galisteo Watershed, more commonly known as the Galisteo Basin, is an extraordinary landscape, reflecting a confluence of geological epochs, ecoregions, wildlife, and human communities past and present. All have left their tracks and trails, creating a crossroads where traditional and contemporary cultures, lifestyles, values, and land ethics converge. As growth comes to Santa Fe County, land use decisions will affect the future of the Galisteo Basin and its residents. With this report, we intend to define, document, and preserve the quality of life embedded in this extraordinary landscape, which lies both literally and figuratively at the crossroads between an Old and New West. Covering 730 square miles just south of Santa Fe, the Galisteo Basin's varied geography includes grasslands, forests, mesas, rolling hills, rocky escarpments, streams, small lakes, and wetlands. The Galisteo Basin lies at the intersection of four western ecoregions: the Southern Rocky Mountains, Arizona/New Mexico Mountains, Southwestern Tablelands, and Arizona/New Mexico Plateau, each contributing to a rich biodiversity. Pronghorn, cougar, mule deer, and black bear occupy the Basin's undeveloped lands, relying on the water resources of Galisteo Creek and its tributaries and wetlands.



The Galisteo Basin is well known for its spectacular views

This area has long served as an intersection of human cultures and populations. Before European contact, the Central Bowl of the Basin supported the highest density of human settlement in northern New Mexico. Evidence of these rich cultures—the largest ruins of Pueblo Indian settlements in the United States, as well as a vast system of rock art—is an archaeological treasure of national significance. Here, the colonial Spanish created some of their most northerly missions, settled small villages, and created many private land grants. These settlement patterns allowed the settlers to graze livestock, develop farms, harvest timber, and explore the area's rich geological formations for turquoise, silver, and gold. Later, and throughout the 20th century, a significant percentage of the Basin lay in large ranch holdings—Ortiz, Ortiz y Pino, Anaya, Simpson, San Cristobal, Thornton, Saddleback, Zorro, Lone Mountain, Cerro Pelon, Thompson, and others.

Changes in the Basin Create a “Growing” Problem. Recent population growth in Santa Fe has led to suburban settlements outside the city's boundaries. The tiny settlements of Cerrillos, Madrid, Galisteo, Lamy, and Cañoncito grew, scattered homes were built in the forested highlands and across abandoned grasslands, and large housing developments appeared along the Basin's highways. Development, mostly concentrated at the perimeter of the watershed — the sensitive higher

ground where drainage systems begin — has triggered environmental problems downstream across the entire landscape, and these problems can be expected to increase if historical growth patterns continue. Roads, fences, rail lines, paving, and housing settlements fragment habitat, create barriers to wildlife migration, increase flood flows, generate erosion, and obscure scenic views. Domestic and community wells deplete groundwater, shrinking wetlands, drying grasslands, and accelerating gully erosion in arroyos and creeks in the process. The Basin’s magnificent night sky is disappearing one light bulb at a time, vandalism threatens archaeological resources, and the scenic and extraordinarily long views of the Basin’s beautiful geologic outcroppings are increasingly obstructed. Clearly, new paradigms for growth management are needed if we wish to ensure the survival of the unique and fragile heritage resources of the Galisteo Basin.

Working Together to Preserve a Heritage Landscape. Several private and public institutions have begun to focus on cultural and natural resource conservation in the Galisteo Basin, including Santa Fe County, which has outlined a program of voluntary measures for land conservation and trail creation. However, to date there has been no collaborative effort to gather, share, or use cultural and natural resource data for the Basin nor create a conservation prioritization strategy that can inform more viable land use decisions in the area. It is our hope that this Galisteo Watershed Conservation Initiative (GWCI) plan will be actively used and updated by land use and transportation planners, resource specialists, conservation organizations, communities, educators, researchers, and individuals who live within or are concerned about the future of the Galisteo Basin and the greater Santa Fe area. It is also our hope that the model will be duplicated and used in other watersheds throughout the state.

Green Infrastructure: Planning for Smart Growth. Across the U.S., communities concerned about ecological, social, health, aesthetic, and economic problems are developing green infrastructure plans. Just as human infrastructure supports human civilization, “green” infrastructure provides essential ecological services on which we all depend and that support our quality of life. Nature’s infrastructure provides the planet with its most fundamental and essential support system: ecological, or life-support, services that underpin all of life, including human activity. Protecting green infrastructure—a network of interconnected natural lands and waters in, through, and around human development—thereby becomes a local and regional approach to solving a national and global problem. By planning for and developing around green infrastructure,



Prehistoric Puebloan rock art in the Basin

habitat fragmentation is reduced, ecological processes are protected, clean air and water are maintained, and recreational opportunities and viewsheds (scenic landscapes) are preserved.

Identifying Conservation Values. The GWCI team identified four “significant conservation values”—water resources, scenic values, cultural resources (historic and prehistoric), and ecological resources (i.e., wildlife habitat)—as primary resources of interest for a conservation plan. We gathered digital geographic data on these four values from diverse sources pertaining to land use, cultural resources, ecological resources, and visual quality resources to create a conservation data “toolset,” the first of its kind for the area. Using Geographic Information System (GIS) software to plot complex data sets as “overlays” on a map, Earth Analytic produced data layers, each representing water, habitat, cultural, or scenic resources, on a series of watershed-wide maps. These layers were then combined into models that can be fine-tuned according to the interest of the user to reveal the cumulative and/or particular values of landscape areas and features, yielding color-coded maps identifying areas of Moderate, High, and Very High conservation priority. In addition to the four conservation values, two land uses were considered as high conservation priorities: working lands (income-producing properties that rely on undeveloped land, such as ranches, farms, outdoor movie sets, etc.) and recreational resources (trails, scenic byways, and outdoor recreation areas).



Galisteo Creek, flowing west toward the Rio Grande

Hubs and Links: Connectivity is the Key. Identifying areas of high conservation interest is not sufficient to form a plan for their preservation. Because fragmentation of habitat, soil erosion, river system damage, migratory route disruption, and other disturbances of ecological processes occur on a landscape scale, it is vital to understand—on a landscape scale—the spatial relationships between priority conservation areas, and to provide for buffers and permanent connectivity between conservation sites. Therefore, the Green Infrastructure Plan in this report identifies “hubs” (sites of high conservation value) and “links” (corridors of open land and/or water that connect hubs). Both must be preserved in order to sustain the ecological services and processes of the landscape as a whole. The Plan identifies that, at a regional and continental scale, the Galisteo Basin serves as a crucial link between several ecoregional hubs. At a local scale, however, the watershed area is made up of seven hubs

(homogeneous landscapes) that are separated by geologic and human-induced barriers and connected via the watershed's network of streams and grasslands. The Plan highlights specifically the local hubs and links within the Galisteo Basin.

Recommendations. These seven hubs and corresponding links, along with data on current protection and restoration efforts, threats and barriers, and land ownership patterns, form the basis for the Galisteo Watershed Green Infrastructure Plan. More data are needed in all of these areas, but even with its data gaps, the Plan is a powerful tool for raising conservation awareness in our communities' priorities. The Plan makes specific recommendations such as community planning processes, strategic land and easement acquisitions, "smart growth" policies, restoration activities, floodplain management approaches, landowner education programs, and strategic partnerships among communities, land-use departments, transportation planners, developers, agricultural interests, landowners, and other watershed stakeholders.



1

INTRODUCTION

Figure 1.1: A Vision Statement for the Galisteo Watershed

(formulated at the community meeting “Paradox and Promise” at Vista Clara Ranch on February 28, 2004)

Residents and stakeholders of the watershed share common values that are the foundation to creating a desirable future. People who live in the Galisteo Watershed want to protect the natural beauty of the land — open spaces, vistas, night skies, wildlife, and solitude. They treasure the creeks that run through the sparsely populated landscape. They want to maintain small scale communities with a culturally diverse group of independent, environmentally conscious neighbors, many of whom live connected to the land. They value the unique historic and cultural heritage of the watershed.

The watershed is a microcosm of the inter-mountain West. Like the rest of the region, people living within the watershed have not heeded the lessons from their past. Climatic cycles and the resulting availability (and lack) of water — and how that water has been managed — is a large part of the reason why the watershed has sustained and not sustained its residents. The economy of the watershed in the past was based on extractive industries that no longer provide an economic engine for the local population. The new economy is a variation on the historic attraction (or is it extraction?) of the watershed — the enchantment with the place and the subsequent value of the land for residential development.

The challenge for the people living in the watershed is how they can live in balance with a fragile, impermanent environment. Thus, what should guide how people in the watershed plan for the future?

- *Growth for commercial and residential development should be ecologically sensitive.*
- *Open spaces and the sense of open space must not be compromised by growth. Any growth should be guided by smart growth (see definition in Appendix A) strategies, including cluster development and mixed use. Ideally, open spaces and villages will be interconnected by trails and public transportation.*
- *Strategies should be undertaken to conserve and preserve important ecological areas.*
- *Water availability should limit all plans for growth.*
- *Appropriate technologies — such as water catchment systems, recycling water, and high tech waste water systems — should be required.*
- *New construction and restoration of existing buildings should utilize environmentally friendly designs and reflect environmental limits.*
- *The watershed should be restored so that the riparian areas are healthy, water flows in the river, and wildlife is abundant. Watershed restoration will require land management strategies such as rotational grazing, grassland restoration, and storm-water management.*
- *Archaeological sites should be protected.*
- *There is a need for a healthy, local economy that fits the custom and culture of the watershed: small-scale, clean, and locally-owned.*
- *Residents of the watershed should participate in decisions likely to affect them. Local decision-making should be the product of regional cooperation reflecting a watershed orientation.*
- *Continuing environmental education — especially for youth — should be a commitment of the communities within the watershed.*

1.1 PARTNERS AND HISTORY

The Galisteo Watershed Conservation Initiative (GWCI) is a collaboration between Earth Works Institute (EWI) and the Santa Fe Conservation Trust (SFCT), in partnership with Earth Analytic, Inc. Supporting partners include the National Park Service (Rivers, Trails and Conservation Assistance Program), Santa Fe County (Planning Division), New Mexico Office of the State Engineer (Interstate Stream Commission), and University of New Mexico (Community and Regional Planning Program).

The GWCI arose as part of a multi-partner effort to support a comprehensive and coordinated approach to preserving the unique scenic, cultural, and natural characteristics of the Galisteo Basin. There is a growing awareness among planners, communities, and conservation groups of an urgent need for an ongoing, integrated planning process for the Galisteo Basin. Since around 2000, many private and public institutions have begun developing and implementing plans for land conservation and natural resource rehabilitation in the watershed. The watershed's center, a grassland ecosystem hub which we call the "Central Bowl," contains such an extraordinary array of archaeological resources that their protection has been mandated by Congress through the Galisteo Basin Sites Protection Act of 2004. In addition, the area is under consideration by the New Mexico Heritage Preservation Alliance as one of the state's "most endangered landscapes" (personal communication from Gary Wolffe, former executive director of the NMHPA, May 2007).

This Initiative began when Santa Fe County identified an open space planning requirement in Santa Fe County's Growth Management Plan (Santa Fe County, 1999) and its Open Land and Trails Plan (Santa Fe County, 2000), both part of the Santa Fe County General Plan. In 2001, Earth Works Institute first identified the need for Geographic Information System (GIS)-driven open space prioritization planning for strategic decision-making on future conservation and restoration interventions in the watershed. In 2003, following Santa Fe Conservation Trust's strategic decision to focus on the Galisteo Basin, Earth Works Institute and Santa Fe Conservation Trust began collaborating to establish a watershed-wide mapping project, which led to a proposal to the New Mexico Legislature in January 2004. Simultaneously, Earth Works Institute led a working group to formulate the Galisteo Watershed Restoration Action Strategy (WRAS) with support from the New



Restoration Ecologist Steve Vrooman discusses wetland restoration issues with a group of workshop participants in the Eldorado Community Preserve.

Mexico Environment Department. One of the recommendations of the Galisteo WRAS Report (July 2005 version) calls for a watershed-wide master plan for green infrastructure. (The WRAS Report is available in the Water & Land Health section of the Earth Works Institute website, www.earthworksinstitute.org.)

The concept of watershed-wide open space planning and prioritization was a central part of the visioning and strategic planning dialogue meetings held at Vista Clara Ranch in 2004-2005, and leading in July 2005 to the establishment of the Galisteo Watershed Partnership (GWP) (www.galisteowatershed.org), a forum for non-profit organizations, government agencies, and landowners concerned about the Basin's future.

The GWCI Green Infrastructure Plan is founded on the group's vision statement for the Galisteo Basin, generated at the February 2004 Vista Clara session (see Figure 1.1). Subsequently, the Galisteo Watershed Partnership helped coordinate the GWCI planning in relation to other initiatives of local and state government agencies, conservation groups, and developers in the watershed. The Galisteo Watershed Partnership focused its May 5, 2006 membership meeting on open space planning in the watershed.

In the fall of 2004, Earth Analytic, Santa Fe Conservation Trust, and Earth Works Institute collaboratively produced a map called the Preliminary Infiltration/Runoff Model for the Galisteo Watershed. The Preliminary Infiltration/Runoff Model project helped the three partners formulate the methodology for the GWCI. Earth Works Institute used the model to develop the project "Planning for Wetlands in the Galisteo Watershed." This collaborative wetlands planning and rehabilitation project has been developed in close coordination with the emerging GWCI. The wetlands project is funded by the U.S. Environmental Protection Agency, coordinated by the New Mexico Environment Department Surface Water Quality Bureau's Wetlands Program, and implemented by Earth Works Institute.

Wetlands and riparian areas constitute the backbone of open space corridors and areas in the Galisteo Basin. As permanent or intermittent sources of fresh surface water, wetlands and streams are historically relevant to the location of archaeological sites, land grants, working ranches, and traditional communities. Wetlands and riparian areas in the Galisteo Basin are crucial wildlife habitat areas and show high ecological diversity. This observation is supported by the February 2006 Comprehensive Wildlife Conservation Strategy for New Mexico, which includes GIS map information that specifies the riparian corridor of the Galisteo Creek and adjacent insular mountain areas and plateaus as priority wildlife habitat for purposes of conservation (New Mexico Department of Game and Fish, 2006). As a result, wetlands and streams are also of great importance for the scenic quality and human experience of the landscape.

1.2 INITIATIVE PURPOSE AND NEED

In the past decades, residents in the Galisteo Basin have faced the impacts associated with rapid population growth, urbanization, and the lingering impact of large-scale natural resource extraction and disturbance of the past 200 years. Until recently, there have been few concerted efforts to address these problems. However, in the face of increasing conversion of rangeland into residential areas, increasing shortages of water for domestic use, rapid disturbance of open space areas, and the increasing awareness of the cultural and ecological value of the watershed area, the need for the preservation of the Galisteo Basin has become apparent.

Over the past decade, various public and private institutions have begun developing and implementing plans for cultural and natural resource conservation in the Galisteo Basin. The Santa Fe County Open Land and Trails Plan (Santa Fe County, 2000) is perhaps the most important landscape-scale resource conservation plan produced to date for the watershed area. The County Open Land and Trails Plan proposes voluntary, not regulatory, measures for land conservation in the context of a series of long-term goals for open land and trail conservation in Santa Fe County.



Wetlands in the Galisteo Basin provide critical wildlife habitat for dozens of species.

These local efforts reflect a national trend. Over this past decade, various universities and national conservation groups such as The Nature Conservancy and Trust for Public Land have developed similar methodologies, largely on a regional scale. However, no such plan had yet been developed for the Galisteo Basin; hence the GWCI study. This Green Infrastructure Plan for the Galisteo Watershed is intended to:

- Assist Santa Fe County, public land management agencies, local conservation organizations, rural communities, and private landowners in the coordination of resource conservation in the watershed
- Compile existing data, reduce the disparity of data sources, provide new data, and develop procedures for collaborative data gathering, storage, management, and utilization for the watershed
- Inform more viable land use decisions
- Establish a prioritization strategy for conservation of open space and restoration areas based on a set of criteria relating to the ecological health of the watershed as well as cultural and historic criteria
- Implement a specific, small conservation restoration pilot project designed to enhance the health of the watershed, and
- Summarize the U.S. GIS map production, the resulting land prioritization, and the implementation of a Conservation and Restoration Pilot Project into a Green Infrastructure Plan for the watershed.

Like Santa Fe County's Open Land and Trails Plan (2000), the proposed Green Infrastructure Plan for the Galisteo Watershed is exploratory and voluntary, not regulatory. The plan echoes the development of green infrastructure plans being created across the U.S. in response to rapid urban development, extirpation of natural resources and ecological landscape functions, and the destruction of wildlife habitat, water resources, and viewsheds. A study published in *Science* in 2002 estimated that "the destruction of habitat costs the world the equivalent of about \$250 billion each year" (Balmford et al., 2002). In their book *Rivers for Life*, Sandra Postel and Brian Richter (Postel & Richter, 2003) emphasize the central ecological role of water bodies such as flood plains and wetlands, and cite Vermont researcher Robert Costanza's (Costanza et al., 1997) estimate that the ecological value of floodplains is about \$8,000 per acre, which translates into nearly \$11,000 per acre at 2007 values (Postel & Richter, 2003). This would mean that the 1,000 acres of present wetlands and streams in the Galisteo Basin represent a value of \$11 million to society, while about 4,000 acres of historical wetlands and floodplain in the watershed have disappeared, at a value of \$44 million.

Green infrastructure goals include the conservation and enhancement of three critical elements: landscape processes, working lands, and open spaces for human benefit. As green infrastructure plans incorporate ecosystem and land use components and processes over space and time, they must focus on landscape-scale approaches to conservation planning. A landscape-scale approach considers how an area's resources "contribute to, interact with, and are influenced by the ecosystems of surrounding areas.... Green infrastructure plans should not only identify a green infrastructure network design, but they also should provide a list of the mechanisms and tools for land protection as well as viable funding programs for reaching plan goals." (Benedict & Bjornlund, 2002).

The open landscape of the Galisteo Basin is gradually fragmenting as a result of property division, highway and railway expansion, and the conversion of farms and ranches into residential areas. Conceived at a landscape scale, green infrastructure plans address the gradual fragmentation of landscapes resulting from exurban development; oil, gas, and mineral extraction; and construction of transportation lines (highways and railways). Fragmentation often jeopardizes space needed to accommodate high stormwater runoff and flood events and leads to isolation of wildlife and a reduction of minimally disturbed, contiguous habitat, eventually jeopardizing biodiversity and species survival. Additionally, fragmentation degrades recreation and viewshed qualities of the landscape as well as architectural and cultural resource relationships.



Urban sprawl near Albuquerque (© 2011 Google)

“One of the factors that distinguishes green infrastructure plans from other conservation plans is that the primary objective is to identify suitable lands for conservation in the context of current and future developed lands. Green infrastructure planning can assist the traditional land use planning process, delineating lands for protection before the allocation of lands for new development. This not only ensures that important natural systems are not fragmented by urbanization, but it also provides a framework for locating new development. Green infrastructure’s comprehensive network design gives conservationists and developers the certainty of knowing which lands are available for development, and which are conservation priorities. Moreover, conservation efforts are much more effective when they are coordinated with growth management and smart growth efforts” (McDonald, Allen, Benedict, & O’Connor, 2005).

Green infrastructure planning that anticipates or reduces the impacts of landscape fragmentation is particularly important in ecological transition zones, such as the Galisteo Basin. The Galisteo Basin lies in a transition zone between four ecoregions: the Southern Rockies to the north, the New Mexico/Arizona Mountains to the south, the Arizona/New Mexico Plateau (including the Rio Grande corridor) to the west, and the Southwestern Tablelands to the east (Griffith, 2006). (See Map 1.1, Ecoregions of the Galisteo Basin.) Transition zones are typical for increased ecological diversity and hydrological activity, which offer opportunities for a working landscape (food and water production), and for cultural richness and visual quality, which offer recreational and educational opportunities. As a transition zone, the Galisteo Basin also connects the lands associated with the Forest Ecosystem Restoration Analysis (ForestERA) mapping and assessment project (ForestERA Project, 2007) and the Southern Rockies Wildlands Network to the north with the New Mexico Highlands Wildlands Vision to the south (Benedict & Bjornlund, 2002). A green infrastructure plan for the Galisteo Basin is, therefore, of regional and perhaps national importance for the conservation of ecological connectivity and biodiversity as well as for the conservation of the rich cultural resources and visual qualities associated with the watershed’s ecosystem.

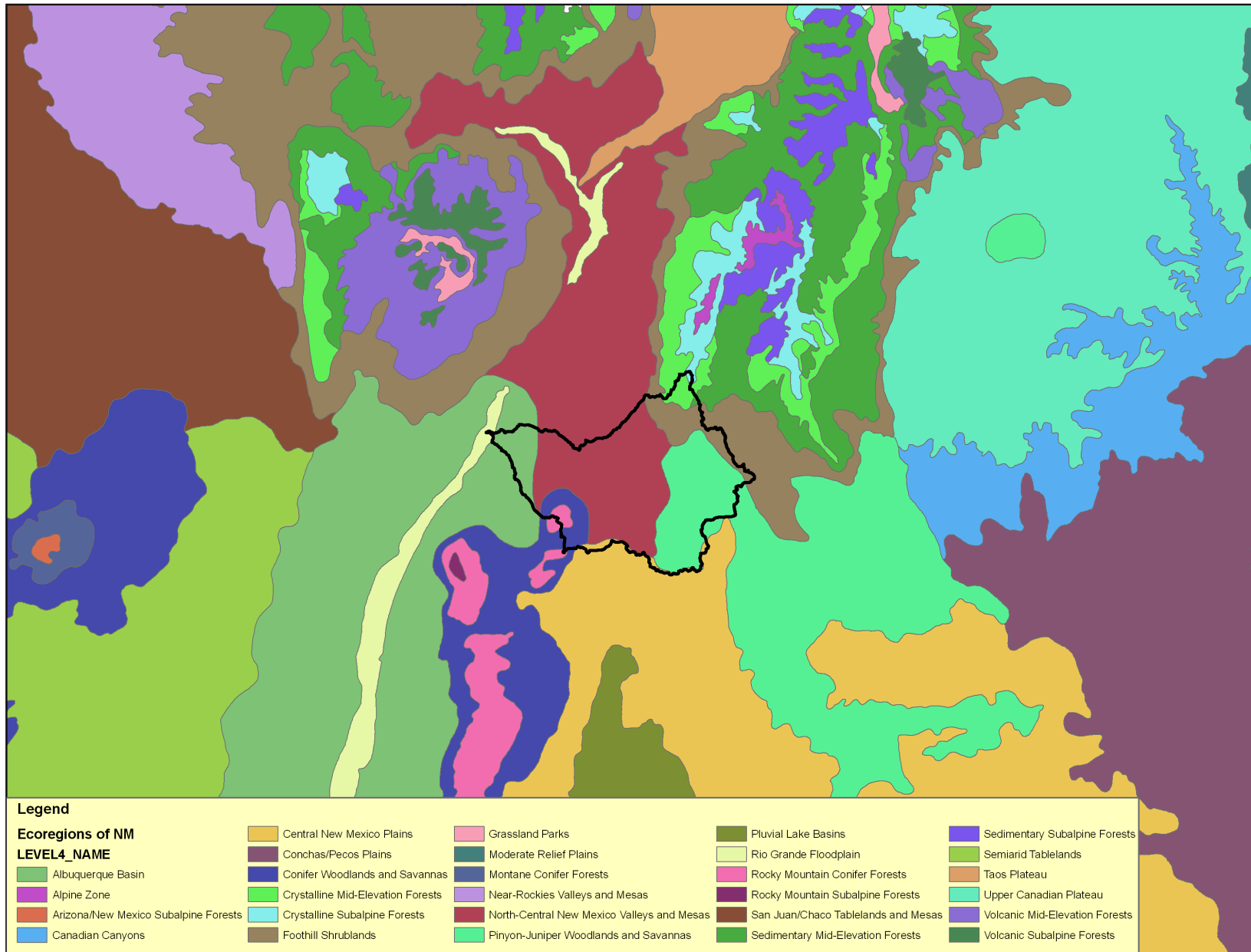

MAP 1.1: ECOREGIONS OF THE GALISTEO BASIN

1.3 INITIATIVE OBJECTIVES

The GWCI was conducted in two parts. The first part was the development of the Green Infrastructure Plan for the Galisteo Watershed and the second part was the implementation of the Conservation and Restoration Pilot Project. Based on this structure, the Initiative objectives were:

1. Green Infrastructure Plan for the Galisteo Watershed: To aid in the preservation of critical landscape values in the Galisteo Watershed by developing a “green infrastructure” open space plan that identifies priority lands for conservation by public and private entities.
2. Conservation and Restoration Pilot Project: To enhance landscape health in the Galisteo Watershed through the design and construction of an effective, low-cost demonstration project that counters the current trend of accelerated soil erosion, degradation of native vegetation cover, and dwindling surface and groundwater supplies.

Expected outcomes consist of a combination of private and public actions including improved stewardship of privately and publicly held lands, the development of conservation easements with individual landowners, well-planned approaches to village growth and resource use issues, and park and open space acquisition by public entities.



Poorly designed culverts and road drainage systems contribute to erosion and ecological degradation throughout the Basin.

The Santa Fe Conservation Trust anticipates using the Plan to raise public awareness regarding preservation of one of North America’s richest landscapes and to identify opportunities for conservation easement partnerships with private landowners. Earth Works Institute anticipates using the plan as a guide to identify and prioritize projects for the restoration of landscape health and the creation of “EcoWise Communities” in the Galisteo Basin. Santa Fe County is interested in using the Plan in developing a strategic plan for managing growth and natural resources in Santa Fe County. Communities in the watershed will find that the Plan can provide both regional and locally specific frameworks in support of thoughtful growth and sustainable resource use. All partners foresee that the model itself, once completed and refined, can be very easily adapted by communities around the state and the Southwest that are interested in sustainable living and enhanced quality of life.

Santa Fe Conservation Trust, Earth Works Institute, Santa Fe County, and the State of New Mexico believe that restoration and conservation work in the Galisteo Basin is important because the watershed landscape is degrading ecologically due to poor resource management, lack of stewardship, and the gradual impact of stormwater runoff, dewatering, erosion, and the collapse of soils and ecosystems. Despite its rural appearance, the cultural landscape of the watershed is no longer a rural, working landscape, but a chain of residential neighborhoods and investment or pleasure ranches. People's connections to the places they own or live on are limited, but as diverse as the origins of the current residents. In some cases this has led to poor land stewardship and many conflicting values about and interests in the fragile landscape.

1.4 INITIATIVE RESULTS, PRODUCTS, AND INTENDED USERS

The data sets generated by the GWCI, which can be expressed in map overlays of qualities pertaining to historical values, surface water resource values, wildlife habitat values, and scenic values, among others, illustrate to some degree the multilayered quality of the landscape. However, the collective of all data sets does not reflect the "multiple senses of place" resulting from the multilayered cultural history of the people in the area (Lippard, 2006). The resulting data sets, therefore, stop short of addressing the differing values and interests that may underlie people's perceptions about the need or urgency for conservation and restoration in the watershed. The findings also do not address the many conflicting values related to cultural differences in land use, attitudes toward land, and concepts of ownership or trespassing and their relation to issues of power and privilege. All these issues will need to be addressed in political and community development processes. The GWCI team believes that the data sets, the digital modeling tool, and the Initiative's recommendations can serve as a valuable resource in planning and decision making processes for the future welfare of the community and the ecological health of the Galisteo Basin landscape.

We urge users of this report (and its associated geographic data and map layers) to interpret the information with careful judgment. The visual appeal, complexity, and volume of data presented should not lead users to believe that we have gathered a complete body of data sets on the geographic and cultural aspects pertaining to land conservation and restoration in the watershed. We also do not pretend to have captured in any way the diversity of values associated with the land.

1.5 INITIATIVE AREA DESCRIPTION

This Initiative pertains to the Galisteo Basin or Watershed, comprised of the surface water drainage basin of the Rio Galisteo or Galisteo Creek. Galisteo Creek drains a 730-square-mile (467,000-acre) area and empties in the Rio Grande at Santo Domingo Pueblo, south of Cochiti Reservoir. The Galisteo Basin is part of the Jemez y Sangre Water Planning Area and is served by the Santa Fe-Pojoaque Soil & Water Conservation District. However, Galisteo Creek is a tributary to the Middle Rio Grande Conservancy District and Middle Rio Grande Water Planning Area. The Galisteo Basin is located immediately south of Santa Fe, New Mexico, and is bounded on the west by La Bajada Hill, Cerrillos Hills, and the heights of San Marcos; on the north by the Sangre de Cristo Mountains; on the east by Glorieta Mesa (sometimes called Rowe Mesa); and on the south by the Ortiz Mountains and the escarpment of the Estancia Basin. The watershed lies across three counties: San Miguel to the east, Santa Fe in the center, and Sandoval to the west.



A volcanic intrusion typical of Basin geology

The Galisteo Basin is characteristic of the many geologic and ecological processes and the many human occupation layers that shaped the landscapes of New Mexico. The contemporary geomorphological contours of the watershed originated in the Upper Cretaceous (more than 65 million years ago) and were subsequently altered by erosion, uplifts, mountain forming, volcanic intrusions, and periglaciation effects, such as sedimentation from mountain streams and wind erosion and deposits. The cultural landscape is comprised of a complex layering of American Indian, Hispanic, and Anglo-American occupation and settlement patterns.

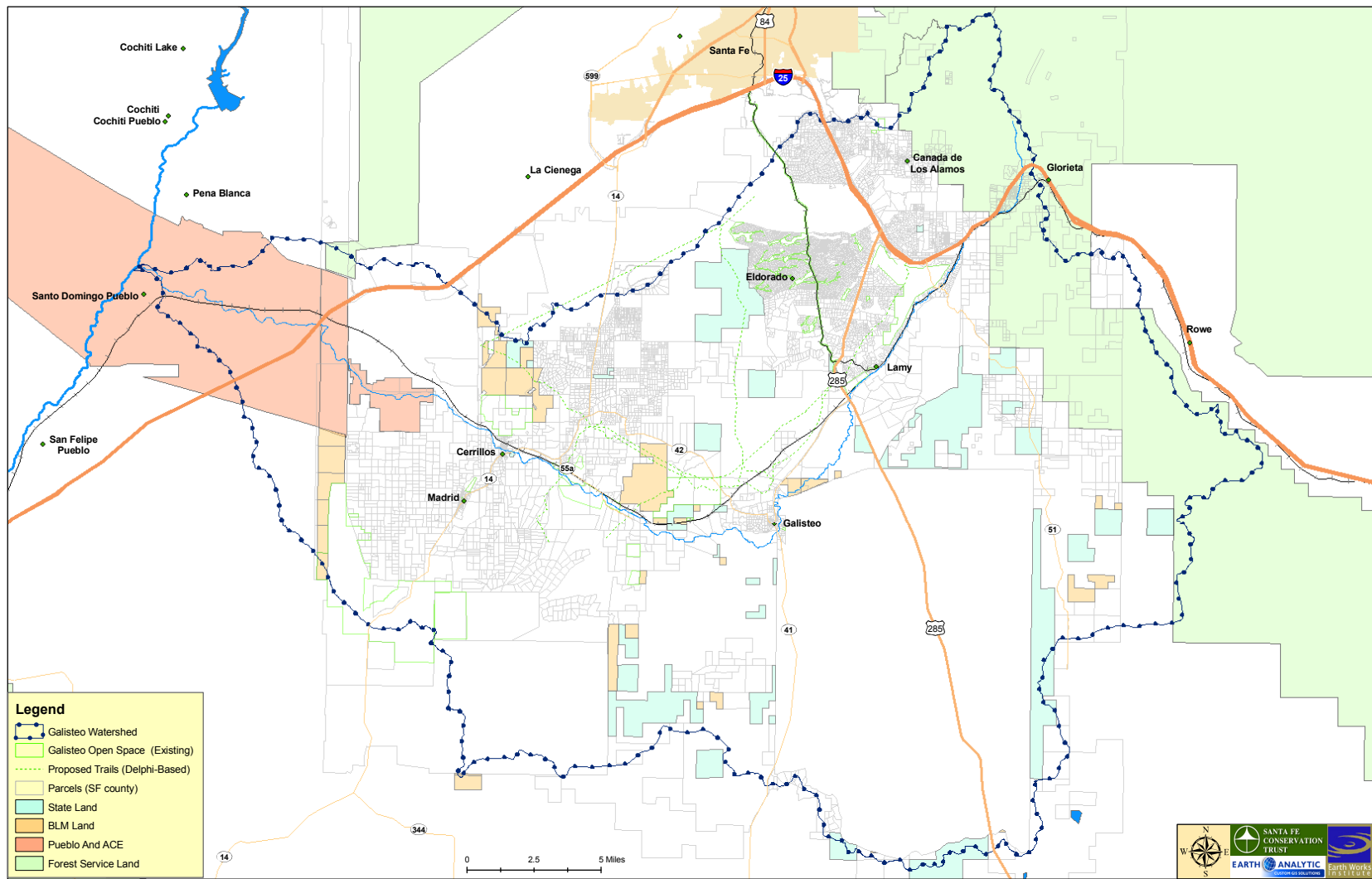

MAP 1.2: BASIN OVERVIEW: LAND OWNERSHIP AND PARCEL BOUNDARIES

The name “Galisteo” refers to both the contemporary Village of Galisteo, near the center of the watershed, and the older Galisteo Pueblo site, a few miles to the north of the village. This name dates back to the 1580-1581 expedition of Captain Francisco Sanchez Chamuscado and Fray Agustín Rodríguez. In September 1581, these Spanish explorers arrived in the area and found several pueblo villages, one of which they named Galisteo, most likely after one of several Spanish villages in Estremadura, Spain (Snow, 1994). In 1601, Juan de Oñate also mentioned “Galisteo Pueblo” in his travel log as a point of departure for a tour of the region (Snow, 1994). In 1706, the name was transferred to a Spanish settlement called Nuestra Señora de los Remedios de Galisteo (“Our Lady of the Remedies of Galisteo”), a few miles south of the former pueblo site. The village was also called Santa Maria (perhaps related to the ranch Los Marias, just north of the Village, currently Vista Clara Ranch). A different source mentions that “the name Galisteo is an old term for a native of Galicia in Spain” (Julyan, 1996). The Spanish settlement was not permanently established until 1814, when the (Mexican) Village of Galisteo was formed after nineteen settlers were awarded a series of individual farm plots (and not the Galisteo Land Grant for which they had applied) (Lippard, 2006).

Prior to the introduction of the name Galisteo, the pueblo — and the larger landscape around it south of the Santa Fe valley — was named after the Tanu (or Tanos): “people who live down country” or “nearer the sun.” To most Tewas, the ancient pueblo and surrounding region were called by a name that could loosely be translated as “the Down-Country Place” (Lippard & Ranney, 2010).



The village of Galisteo, which was founded in 1706, is still located on the banks of Galisteo Creek. A nearby volcanic dike plays a role in supplying water for the village. (Photo courtesy of Greenheron47 at Flickr.com)

Until the 1970s, the Galisteo Basin was a relatively remote, rural area with very little human habitation and few roads. It was considered and treated as a “back-yard area” for the City of Santa Fe and was given very little attention in planning and land conservation. Flooding and erosion led to the first resource conservation measures in the form of levees and dams, the first dating from the construction of the Atchison, Topeka and Santa Fe Railway in 1880. Other water control structures followed in the 1930s, the 1950s, the 1970s, and works built between 1995 and the present. Flooding also led to the construction of the Galisteo Dam in 1975, and to its alterations in 1998. Also in 1998, the New Mexico Highway and Transportation Department paved portions of the Interstate 25 median in Cañoncito, which relocated certain flooding and erosion problems from upstream to downstream. Since the 1970s, certain ranches have also implemented small-scale soil and water conservation practices.

The first large-scale conservation measure in the watershed was in 1892 with the establishment of Forest Reserve lands (now called National Forest). Today approximately 45,272 acres of National Forest lands are within the watershed. Later, larger-scale conservation measures include the implementation of the Galisteo Watershed Restoration Project (after 1998), the establishment of protected sites under the County Open Space and Trails Program (after 2000), the establishment of the Cerrillos Hills Historic Park (January 2000), the establishment of private conservation easements (1990s-present), and the 2004 Galisteo Basin Archaeological Sites Protection Act (S.210, H.R.506). Map 1.2 illustrates the currently existing open space and protected public lands in the Galisteo Basin.

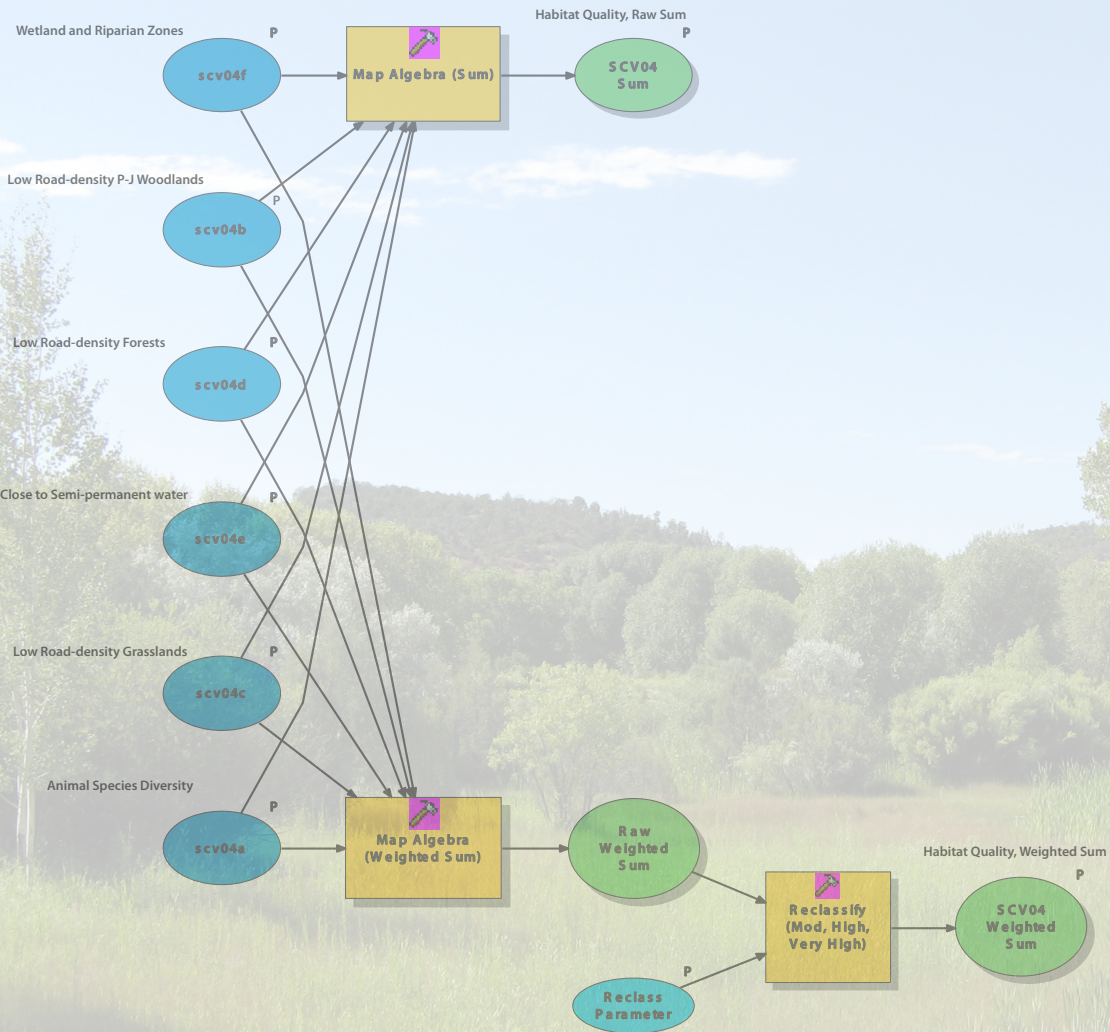

2

METHODS

The Galisteo Watershed Conservation Initiative (GWCI) is divided into two parts. The first part is the development of the Green Infrastructure Plan for the Galisteo Watershed and the second part is the implementation of the Conservation and Restoration Pilot Project. Both this section and the following Results section are divided into these two parts.

2.1 METHODS: GREEN INFRASTRUCTURE PLAN FOR THE GALISTEO WATERSHED

The methodology for the Green Infrastructure Plan is described in detail in Appendix D. Following is a summary overview that outlines Plan activities as presented in the work plan agreement with the State of New Mexico.

The Green Infrastructure Plan methods included:

Task 1: Developing a Method and Steering Committee

- a. Contacting concerned parties and forming a steering committee
- b. Establishing a data sharing system
- c. Developing methods

Task 2: Developing GIS Maps for Analysis

- a. Creating a GIS database for the watershed
- b. Creating GIS maps for Green Infrastructure Plan

Task 3: Developing a Prioritization of Open Space Options and Acquisitions

- a. Outreach meetings – input on maps
- b. Developing prioritization of open space options

These tasks are described later in this section.

The final SCVM output includes the following four Composite Models and their subsequent components (see also Appendices D, E, and K):

SCV Wrap-Up Model (Sum with 13 value categories, Weighted Sum with 3 value categories)

SCV02 Scenic Value (composite)

SCV02a Scenic Grasslands

SCV02b Scenic Riparian Areas

SCV02d Scenic Landmarks

SCV02e Scenic Piñon-Juniper Woodlands

SCV03 Cultural Resource Value (composite)

SCV03a Existing Archaeological and Historical Area Buffers

SCV03b Registered Properties and Galisteo APA Sites

SCV04 Habitat Value (composite)

SCV04a Animal Species Diversity

SCV04b Piñon-Juniper Woodlands

SCV04c Grasslands

SCV04d Forests

SCV04e Areas Near Semi-Permanent Water

SCV04f Wetland and Riparian Zones

SCV05 Water Value (composite)

SCV05a Drainage Buffers

SCV05b Water Bodies

SCV05c Wetland and Riparian Zones

SCV05d Spring Buffers

SCV05e Aquifer Recharge Zones

The GWCI team decided to expand Task 2 (Developing GIS Maps for Analysis) with a GIS feature called “zonal statistics,” which allows users to apply the open space prioritization overlays on a parcel level (see the Developing GIS Maps for Analysis subsection and Appendix E for details). This application generates for each selected parcel a weighted value of the natural resource categories of the GWCI open space plan. This application is useful to those who want to make a prioritization of land conservation or rehabilitation measures based on values present in specific parcels rather than at the level of ecological terrain units across the landscape and across ownerships.

Data collection took place as part of the GIS data set development process and as part of the expert feedback process. Additionally, the GWCI team recorded public feedback during presentations for the Galisteo Watershed Partnership (see below).

GIS data collection, analysis, and management are explained in detail in Appendix E. Data recorded in reports from expert meetings is included in Appendix F. SCV maps can be found in Appendix K.

The authors conclude that the Galisteo Basin area is poorly studied and poorly documented. As local historian and author Lucy Lippard put it, “The Galisteo Basin is a famous place about which little is known, and less written, although myths abound” (Lippard, 2006). Lippard attributes this to the strong influence of a tradition of oral transfer of knowledge among areas of Hispanic and Native American populations. Quoting a native, Lippard writes “Most educated people say, ‘where is it written?’ Our people say ‘where is it *lived?*’” (Lippard, 2006).

This paucity of written and mapped information for the Galisteo Basin has been only partly filled with recent documentation supported by digital (GIS) data gathering and representation. As a result, many newer data sources and data sets cover only a part of the watershed, or specific aspects of the landscape. Additional interpretation is needed in order to arrive at a proper prioritization of an open space network for the purpose of this study. Lippard has observed this problem as well, and quotes Ernest Bloch and Gwen Wright in calling this phenomenon the existence of “non-synchronisms,” which they define as “the coexistence of tradition and innovation in all people’s lives; of different, even opposing cultures living alongside one another; of inequalities and tensions that sustain any social stability, even as they lay the groundwork for change.” She concludes: “That describes life in Galisteo very well” (Lippard, 2006).

Task 1: Developing a Method and Steering Committee

CONTACTING CONCERNED PARTIES AND FORMING A STEERING COMMITTEE. The first step in developing the Green Infrastructure Plan was to establish a steering committee consisting of GIS, conservation, and planning experts. These initial members formed the core of the GWCI team. That team contacted GIS expert staff at various local, state, and

federal government agencies to inform them about the project. Earth Works Institute then formulated a general planning methodology and Earth Analytic, LLC, developed a GIS methodology.

ESTABLISHING A DATA SHARING SYSTEM. The Significant Conservation Value Model (SCVM) and associated models and data layers developed for the GWCI are currently stored at the offices of the Santa Fe Conservation Trust, Earth Analytic, and Santa Fe County. At the time of this writing, the Santa Fe Conservation Trust is exploring the possibility of transferring storage and management responsibilities of the SCVM and associated data sets to Santa Fe County. Additionally, the Trust is exploring the possibilities of making the project's entire GIS output available on a CD ROM, via a website, and at the State Library.

DEVELOPING METHODS. The planning method started with a definition of Open Space so that the GWCI team could identify and categorize all existing open space and trails (protected vs. unprotected and private vs. public) (see Appendix A, Terms and Acronyms). That step will ultimately lead to the development of separate data sets for different kinds of open space that can be combined in one map.

This task was followed by a preliminary open space suitability assessment to identify Significant Conservation Value (SCV) areas. SCV areas include those that meet selection criteria for high values of aesthetics (visual and spiritual values, etc.), land health (ecological functionality), recreation, land use patterns, public uses, rural economic development opportunities (agriculture and other non-urban, non-industrial economic development), and cultural resources. The objective was to identify undeveloped lands — not including existing open space — having significant conservation value, and to rank these areas in terms of relative conservation value (or conservation priority). In the initial methodology, the following six SCV areas formed the basis of this process:

- SCV-1: Recreational Opportunities
- SCV-2: Scenic Values
- SCV-3: Significant Archaeological, Historical, and Paleontological Resources
- SCV-4: Significant Habitats
- SCV-5: Water-holding, Absorption, and Conveyance Zones
- SCV-6: Working Lands

In the initial methodology, Models SCV-1 through SCV-6 were to be combined to generate Model SCV-7: Combined Conservation Priority. Model SCV-7 was to consist of a weighted result of all six models. In this step, all six sub-models have an equal weight. The next section will describe some modifications made to this initial SCV methodology.

Task 2: Developing GIS Maps for Analysis

The GWCI Green Infrastructure Plan and the supporting maps are based on a Geographic Information Systems (GIS) data modeling and analysis. The GIS task component is described in detail in Appendix E. The GIS task included:

1. Collecting GIS data for currently protected “open space” (with separate data layers for public lands)
2. Collecting GIS data for undeveloped lands—not including existing open space—of significant conservation value (SCV), and the ranking of these areas in terms of relative conservation value (or conservation priority)
3. Identification of the application of the SCV prioritization outcomes at a parcel level through zonal statistics

The GIS task has generated a geographic data analysis and evaluation tool and a set of data output raster models, which can be printed in map format. The geographic data analysis and evaluation tool of the GIS task includes a hierarchical geoprocessing model for data layers constituting SCV areas. Geoprocessing models are analytical constructs that provide a flowchart interface for exposing sequences of GIS processes along with explicitly defined analysis parameters. Geoprocessing models are easily modified to incorporate new data and to evaluate different parameters, making them useful tools for long-term planning and research.

We termed the model developed for the GWCI the Significant Conservation Value Model (SCVM). As a GIS-based hierarchical geoprocessing framework, the SCVM was built with ESRI’s ArcView 9.2, the Spatial Analyst extension, and the embedded ModelBuilder component of ESRI’s ArcGIS software line.

The SCVM structure takes advantage of the relative path references of ArcGIS 9.x map documents, toolboxes, and model outputs, allowing the user to make a copy of the entire default scenario folder. By changing the name of a new scenario folder and renaming the map document and model toolbox contained therein, the user can open the map document, reset the environment settings as necessary, and then manipulate the models as desired. Importantly, this scenario-building effort does not require duplication of the model input data, which is stored in a folder called ModelInput, located at the same directory level as the root scenario folder. The SCVM toolbox is subdivided into three primary toolsets: one for data preprocessing, one for the hierarchical basin-wide conservation model, and one for post-modeling analysis.

The SCVM hierarchy consists of four primary geoprocessing models (i.e., composite models):

1. Scenic Value
2. Cultural Resources Value
3. Habitat Value
4. Water Value

Composite Models (e.g., overall Habitat Value) combine the results of two or more secondary geoprocessing models called Component Models (e.g., animal species diversity, low-road-density grasslands). The models are implemented in sequence for each thematic category: all Component Models are run first, followed by the Composite Model. The results of the four Composite Models are combined in the SCV Wrap-up Model. The Composite Models and the SCV Wrap-up Models generate two raster outputs, one based on a simple sum operation and another based on a weighted sum operation that also reclassifies results into three ordinal classes (Moderate – High – Very High, regarding the prioritization of the composite, weighted Significant Conservation Value). (See Appendix E for a detailed description of classification and weighting methodology.)

For the current analysis, equal weights were applied to all input criteria for all models. In future applications or in other locations, these weights can be adjusted on the fly for use in evaluating different funding and conservation priority scenarios.

While the SCV Wrap-up is perhaps most important for generating the final Green Infrastructure Plan, each individual Composite Model can be assessed and utilized independently. These models can be adjusted in many ways, from the vintage or accuracy of input data sets to the classification schemes and parameter settings (e.g., buffer distance, richness value threshold). The models can also be enriched with additional component models and/or compared in overlays with specific land use models (e.g., recreational use, working ranches, or real estate appraisal values) for additional analysis purposes.

The initial SCVM toolbox included SCV01 Recreation Value and SCV06 Working Lands (ranches and farms). However, during the SCVM development and analysis process, the GWCI team decided to eliminate SCV01 and SCV06 from the model because, while they are based on ecological and cultural landscape values that create the suitability of these land uses, these data sets represent land uses rather than ecological and cultural landscape values. Inclusion of these two models would have contributed to an implicit double counting and associated bias in favor of the ecological and cultural landscape values they embody. The GWCI team decided instead to use the SCV01 and SCV06 models as separate data layers that can be used for additional analysis purposes.

Certain component models were used in different forms in more than one composite model, such as the GAP vegetation data set for grassland values in both the Scenic Value and Habitat Value models. The GWCI team felt that this was appropriate to arrive at the true composite sum value for each composite model. This implicitly means that certain aspects of the Galisteo Basin — grasslands, wetlands, water bodies, riparian areas, and woodlands—are valued in several models, and therefore contribute to high cumulative values for these landscape features in the composite sum and weighted sum output models (maps). Similar procedures were followed after input from the archaeological expert team to enhance the relative value of specific archaeological sites. The GWCI team felt that this approach was appropriate, as these features largely determine the diverse and rich conservation values of the Galisteo Basin landscape.

The GWCI has generated a series of data outputs in the form of maps for specific data sets deemed relevant for the development of the Green Infrastructure Plan. The data outputs fall in the categories of preprocessing outputs, SCVM outputs, and parcel-level post-modeling analysis. See Table 2.1 for a list of output maps, and Appendix K for SCV maps.

Table 2.1 GIS Maps for Green Infrastructure Plan

PREPROCESSING OUTPUT MAPS
<ul style="list-style-type: none"> Hydro model: combination of drainage, water body, and spring data sets
<ul style="list-style-type: none"> Low road density areas (based on the assignment of a value of 1 to cells falling within square-mile blocks that have less than one linear mile of paved roads per square mile)
<ul style="list-style-type: none"> Protected open space lands (consisting of conservation easements held by the Santa Fe Conservation Trust, the Taos Land Trust, or The Nature Conservancy; parcels in the Santa Fe County database classified as/known as common area, park, trail, open space, or conservation easement, including the Eldorado Wilderness; and a state and federal lands data layer)
<ul style="list-style-type: none"> Soil data (based on a combination of SSURGO data sets for San Miguel County, Santa Fe County, and Sandoval County)
<ul style="list-style-type: none"> Recreation model (e.g., presented as an overlay on some of the Composite maps included in this report)
SIGNIFICANT CONSERVATION VALUE MODEL MAPS (SEE APPENDIX K)²⁴
<ul style="list-style-type: none"> Scenic Value – composite (unweighted)
<ul style="list-style-type: none"> Scenic Value – composite (weighted sum)
<ul style="list-style-type: none"> Cultural Resource Value – composite (unweighted)
<ul style="list-style-type: none"> Cultural Resource Value – (weighted sum)
<ul style="list-style-type: none"> Habitat Value – composite (unweighted)
<ul style="list-style-type: none"> Habitat Value – composite (weighted sum)
<ul style="list-style-type: none"> Water Value – composite (unweighted)
<ul style="list-style-type: none"> Water Value – composite (weighted sum)
<ul style="list-style-type: none"> Significant Conservation Value Wrap-Up Model

The SCVM process has been geared strongly to the development of a prioritization scheme for the conservation of open space areas of significant conservation value in the Galisteo Basin. However, this analysis process did not lead directly to a green infrastructure plan for the watershed, as it did not explicitly identify the existing spatial structure of the landscape and the qualities of the spatial structure for the valuation of open space. Spatial structure was addressed implicitly, however, by identifying undisturbed areas based on paved road density and using this criterion as a qualifier for the conservation values of grasslands, woodlands, and forests. Spatial structure is typically characterized as open space “hubs” (core areas) and “corridors” (linking areas between the hubs). The hubs are large contiguous areas of undeveloped lands, and as such have conservation value, while the corridors serve to link hubs for wildlife movement, water flow, and/or scenic or recreational connections between hubs. A description of open space hubs and corridors and their relation to the SCVM output is included in the Methods section. An overview of data sources used, metadata for the sources, and a model summary that explains how each component model was derived from the data sources is included in the SCVM explanation in Appendix E.

Task 3: Developing a Prioritization of Open Space Options and Acquisitions

The GWCI team classified the prioritization output for the plan based on four attribute categories and the cumulative sum, the cumulative weighted sum, and/or the cumulative double-weighted sum of the attributes and their sub-models. Simply put, the conservation value of an area was considered higher if more landscape attributes were found to be present in that area. The weighted and double-weighted sum categories are expressed in three categories of Significant Conservation Value: Moderate, High, and Very High.

The cumulative sum output map offers a representation of the direct sum of all models resulting in more than twenty output value classes in the map legend. This gives users of this report the option of a finer scale of classes of significant conservation values to judge prioritization of open space conservation acquisitions. The GWCI team did not come to agreement on a variable weighting procedure that allows for different weights for different SCV models. The team concluded that equal weights should be maintained among the four models as offered in the basic SCV methodology. Users can modify the weighting as they desire.

Expert Review and Feedback

In early 2006, the GWCI team convened a series of meetings with experts in four different teams related to four specific land attributes to obtain feedback on the preliminary SCV models. The four expert groups covered 1) cultural resource areas, 2) natural resource areas, 3) scenic resource areas, and 4) water resource areas. The groups offered extensive lists of recommendations on data gaps, the need to identify conservation buffer zones or corridors, the need to modify the

weighting of data layers, and ways to increase the usefulness of the map data. Detailed reports on expert feedback are presented in Appendix F.

Public Feedback

The GWCI team received public feedback through a series of quarterly meetings of the Galisteo Watershed Partnership (GWP) in 2007 and 2008. The meetings were open to the public and advertised via a limited e-mail list, a website, and newspaper announcements.

The meetings were not specifically organized to receive feedback on the GWCI draft plan. However, the meetings addressed specific issues of interest to the GWP members and interested public, which were of direct importance to the GWCI planning outcomes. Agenda items addressed by specialists and County staff included:

- How does the Santa Fe County development review process work and what financial incentives exist for ranch conservation?
- What is the state of the art of water planning in relation to growth management planning in the Galisteo Basin?
- What is desirable urban development in the Galisteo Basin and surrounding areas?
- In the view of those who live there, what are the most important open space areas or hubs (places of “Querencia” or “places of the heart”)?
- What are the conditions of wildlife and its habitat in the Galisteo Basin, and what wildlife conservation needs and strategies do people identify?

Developing Prioritization of Open Space Options

In addition to the Preprocessing and SCVM, several models were developed to facilitate quantitative assessment of conservation values for specific parcels. For example, the “Easement Target Model” uses the weighted sum output from the Significant Conservation Value Wrap-Up Model as the basis for identifying parcels intersected by contiguous one-acre-plus zones of maximum conservation value (Very High, score 3). More specifically, the model selects cells classified as “Very High” from the weighted sum output from the Wrap-Up model, defines contiguous blocks of these cells, and then further subdivides the output into contiguous blocks of high-scoring cells using the region group and zonal geometry functions. Finally, the model runs zonal statistics on the intermediate output with the parcel data set, identifying parcels

that intersect these contiguous blocks of high-scoring cells. The output of this model is shown in Figure E-1 in Appendix E. Appendix E also includes an explanation of the modeling process, a description of zonal statistics analysis, and examples for queries to identify SCVM outcomes at a parcel level.

2.2 METHODS: CONSERVATION AND RESTORATION PILOT PROJECT

The second component of the Galisteo Watershed Conservation Initiative of 2004-2007 was the planning, design, and implementation of a conservation pilot project based on the Green Infrastructure Plan's conclusions and recommendations. The purpose of this implementation component was to ensure that some of the appropriated funds were used for on-the-ground terrain improvements. Additionally, the pilot project implementation phase served to evaluate planning outcomes and verify that the Green Infrastructure Plan was ready for practical implementation.

The pilot project's methods are divided into the following six tasks:

Task 1: Site Selection

Task 2: Project Planning

Task 3: Developing a Monitoring Plan

Task 4: Designing the Project

Task 5: Implementing the Project

Task 6: Conducting Conservation and Restoration Pilot Project Monitoring

Site Selection (Task 1)

Step 1: Site Selection Protocol and Criteria. The first step in the planning process for the conservation pilot project was the development of a pilot site selection protocol. This protocol leaned strongly on the prioritization protocol that had been developed based on the GIS data analysis and modeling component of the Green Infrastructure Plan (i.e., the SCVM).

The Earth Works Institute (EWI) team undertook the development of the conservation pilot project and developed site selection criteria as part of the pilot site prioritization protocol (see Table 2.2).

Step 2: Ranking by Significance Score. The second step of the conservation pilot site selection protocol included a review of sites in the SCVM categories “High” and “Very High” for which Earth Works Institute and Santa Fe Conservation Trust had either (1) received requests for the consideration of implementing conservation and/or restoration projects or (2) undertaken detailed site assessments in relation to the project “Planning for Wetlands in the Galisteo Watershed.” The following sites were identified from this second selection step:

- The riparian corridor and associated wetlands of the Galisteo Creek in the Village of Galisteo, including the oxbow wetland on the Cerro Pelon Ranch
- Springs, wetlands in arroyos, wet meadows, and geologic features on the Galisteo Basin Preserve
- Springs, wetlands in arroyos, wet meadows, geologic features, and archaeological sites on Glorieta Mesa (especially associated with the Arroyo Salado on Beneficial Farm)
- Springs and wetlands in arroyos in Upper Cañoncito along I-25
- The wetlands, wet meadows, and historic sites associated with the Finger Lakes on the Three-Horse Ranch and La Jara Ranch properties
- Wetlands and associated archaeological sites in the San Marcos Arroyo.

Table 2.2 Conservation Pilot Site Selection Criteria

A PROSPECTIVE PILOT CONSERVATION SITE:
<ul style="list-style-type: none"> • Scores High or Very High in the 3-value classification of the SCV analysis and is in need of (additional) conservation measures (e.g., can be protected with a conservation easement and/or a combination of other conservation tools, as listed in Section 4.1, Conservation Tools Recommendations)
<ul style="list-style-type: none"> • Contributes to the integrity of one of the Green Infrastructure hubs in the Galisteo watershed (i.e., it strengthens the key characteristics of the hub, as listed in the Green Infrastructure Plan)
<ul style="list-style-type: none"> • Preferably includes a wetland or riparian zone in order to leverage the mutual impact of the ongoing NMED/EWI wetland project and the GWCI pilot site
<ul style="list-style-type: none"> • Leverages protection of adjacent protected open space and SCV areas and/or strengthens, expands or protects existing corridors and buffer zones in the Green Infrastructure Plan
<ul style="list-style-type: none"> • Is under ownership of landowners or land managers who are willing and able to support the implementation and stewardship activities required for the longevity of the conservation pilot project
<ul style="list-style-type: none"> • Offers technically feasible opportunities for the planning, design and implementation of the pilot project (e.g., the site is accessible; site rehabilitation is technically and financially feasible within the means of the project)
<ul style="list-style-type: none"> • Has clear ownership title
<ul style="list-style-type: none"> • Is under ownership of an entity or individual who has the ability to contribute to at least 10% of the site restoration costs, who has a long-term stewardship commitment, and who is willing to provide access for monitoring, public (and school) education, and other demo/outreach functions.

Step 3: Ranking by Feasibility. The third and final step in the selection process included a pragmatic evaluation of the feasibility of the prospective conservation pilot sites. Within the limitations of the GWCI’s time and budget, the GWCI team agreed with Earth Works Institute to select a small, degraded wetland site in a geologically spectacular arroyo on the Galisteo Basin Preserve.

Project Planning (Task 2)

The project team consisted of EWI staff members and Steve Vrooman, a contractor for EWI specializing in ecological restoration design. The unnamed drainage selected for this project flows into the Arroyo de los Angeles, approximately 200 yards downstream from a windmill near what is called the “Cowboy Shack.” The project team named this arroyo the Southwest Arroyo and conducted a site assessment of the drainage’s biological and geomorphic conditions. Subsequently,

the project team specified its goals for the ecological restoration of the drainage. The goals were to raise the channel bottom by 6-8 inches in order to allow greater over-bank flooding and expansion of the wetland area by at least 100%, effectively doubling the size of the area that has significant wetland conditions.

Additionally, the project team coordinated with the landowner, Commonweal Conservancy, and the Santa Fe Conservation Trust regarding the potential for establishing a conservation easement around this restoration site to protect the area and the ecological restoration investment. The Santa Fe Conservation Trust had begun conversations with Commonweal Conservancy about the establishment of a conservation easement program for the 12,000-acre open space area of the Galisteo Basin Preserve, which includes the conservation pilot site. Both parties agreed to proceed with the implementation of the open space protection strategy with conservation easements after County approval of the Galisteo Basin Preserve master plan. EWI, Commonweal Conservancy, and the Santa Fe Conservation Trust agreed to proceed with implementation of the pilot demonstration site in anticipation of County approval of the master plan and the establishment of one or more conservation easements on the Preserve.



Restoration Ecologist Steve Vrooman teaches Charter School 37 students about wetland restoration options in the Southwest Arroyo.

Developing a Monitoring Plan (Task 3)

The EWI project team developed a monitoring plan to measure progress in site rehabilitation and protection and to develop site-specific information for education and outreach about specific rehabilitation and conservation measures suitable for the Galisteo Basin Preserve. Specific monitoring components and criteria included:

- Ecological: geomorphological balance and hydrology (creek width/depth ratio, sinuosity, grade, signs of erosion or aggradation); vegetation cover and richness, especially pertaining to ecosystem keystone species (e.g., wetland plants); soil characteristics (structure, wetland characteristics); wildlife observations
- Cultural: people's interest in the place; public learning opportunities
- Stewardship: people's investments in the land's health and ecological productivity
- Land use: adherence to the terms of the conservation easement

Designing the Project (Task 4)

The EWI project team identified, designed, and staked out a series of biotechnical stream stabilization techniques for specific locations in the drainage. Subsequently, the team applied for a Clean Water Act Section 404 permit and a clearance from the State Historic Preservation Officer.

Implementing the Project (Task 5)

The project team hired Craig Sponholtz and Steve Vrooman to implement the project. Implementation was done by machine (transportation and placement of rock) and by hand (precision rock stacking and final finishing and grooming of the site). Implementation took place between December 2007 and March 2008.

Monitoring (Task 6)

The project team anticipated that monitoring would be performed by Charter School 37, UNM students, and Earth Works Institute staff. Monitoring would take place in the spring and fall of each year, and be part of additional wetland monitoring activities throughout the Galisteo Basin. As time progressed, Charter School 37 only conducted quantitative baseline monitoring (stream measurements) under the supervision of EWI staff. Follow-up monitoring was conducted by EWI staff only, consisting of stream measurements and photo points (permanent points for photo monitoring).



3

RESULTS

3.1 RESULTS: GREEN INFRASTRUCTURE PLAN FOR THE GALISTEO WATERSHED

Overview of Plan

The development process for the Galisteo Watershed Green Infrastructure Plan followed a common planning approach. The technical planning components of our planning process are also common to the general green infrastructure planning process and have been discussed in Section 2.0, Methods. The public involvement component of the planning process included:

1. Stakeholder identification and organization and the development of a decision making mechanism (Green Infrastructure Plan Task 1).
2. Formulation of a vision and mission (already conceived prior to the project in the County Open Lands and Trails Planning process in 1999-2000, the planning processes of the Galisteo Watershed Partnership — GWP — in 2004-2005, and the Watershed Restoration Action Plan process of 2003-2005), and reiterated in the GWCI proposal and Task 1 (see Appendix D).
3. Public involvement (addressed in GWP meetings and in Task 3 of the Green Infrastructure Plan methods).

The results of the first part of the GWCI can best be characterized as a preliminary, conceptual plan for a green infrastructure in the Galisteo Basin, with an emphasis on a prioritization strategy for the conservation of open space areas. The plan describes a vision for the desired future green infrastructure for the watershed, indicates priority areas for conservation, and offers suggestions for the implementation of conservation measures. The plan is meant to stimulate public dialogue, for example through existing channels of public input for lands managed by public agencies or through the mediation of the Galisteo Watershed Partnership.

The public involvement component of the GWCI planning process has been limited to expert input (Task 3) to the preliminary GIS data output (Task 2) and presentations of plan findings at meetings of the Galisteo Watershed Partnership throughout 2006. The GWCI team anticipates that after its completion, the plan will serve to launch additional public dialogue meetings, which may then lead to plan updates and partial implementation.

The current Green Infrastructure Plan for the Galisteo Watershed is, therefore, a living document that stimulates planning as a community-driven learning process rather than prescribing a desired future condition of the landscape. Over the past 20 years, community and regional planning has gradually moved from an end-goal-oriented approach to a process-

oriented approach, of which this Green Infrastructure Plan is an expression. This approach accepts that we cannot control the future, but that we can stimulate an iterative, collective learning process that will mobilize public support in order to encourage individual landowners and land developers to make decisions for the conservation of landscape values. In addition, this approach can encourage public officials to enact public land management decisions that work toward the implementation of the Green Infrastructure Plan. As time progresses, parts of the plan may change as our collective or individual preferences and viewpoints change and as opportunities arise or disappear.

The Proposed Green Infrastructure

The Green Infrastructure Plan Vision

The proposed Green Infrastructure Plan for the Galisteo Watershed takes the vision statement of the community planning dialogue of February 28, 2004 as its starting point (see Figure 1.1). This vision statement, which lists what people treasure about the watershed, corresponds with the four SCV models (i.e., mapping layers) as described in the Methods section. The list states:

Residents and stakeholders of the watershed treasure:

- The natural beauty of the landscape (open space, vistas, night skies, solitude)
- Access to open space
- Wildlife
- The Galisteo River
- A diverse, functioning ecosystem
- That the people who live in the watershed are independent thinkers, engaged, and environmentally conscious. Many people live in a way that is connected to the land.
- The relaxed rural character
- The rich historic and cultural heritage

Other crucial values for the Green Infrastructure Plan excerpted from the vision statement include:

- People want to protect the natural beauty of the land: open spaces, vistas, night skies, wildlife, and solitude. Strategies should be undertaken to conserve and preserve important ecological areas. Open spaces and the sense of open space must not be compromised by growth. What growth does occur should use smart growth strategies, including cluster development and mixed use. Ideally, open spaces and villages will be interconnected by trails and public transportation.
- They treasure the creeks that run through the sparsely populated landscape. The watershed should be restored so that the riparian areas are healthy, water flows in the river, and wildlife is abundant.
- They want to maintain small-scale communities with a culturally diverse group of independent, environmentally conscious neighbors, many of whom live connected to the land.
- They value the unique historic and cultural heritage of the watershed. Archaeological sites should be protected.

Categorization of Landscape Attributes for the Green Infrastructure Plan

As described in the Methods section, the Green Infrastructure Plan for the Galisteo Watershed is primarily based on four landscape attribute categories that relate to open space values (which correspond with the values expressed by participants in the vision statement meeting):

- Water attributes
- Habitat attributes
- Cultural resource attributes
- Scenic attributes

The GWCI team classified the prioritization output for the plan based on these four attribute categories and the cumulative sum, the cumulative weighted sum, and/or the cumulative double-weighted sum of the attributes and their sub-models. Simply put, the conservation value of an area was considered higher if more landscape attributes were found to be present in that area. The weighted and double-weighted sum categories are expressed in three categories of Significant Conservation Value: Moderate, High, and Very High.

In the Galisteo watershed's GWCI/SCVM output, features tend to cluster within one of these three categories:

Moderate:

- Most grasslands, woodlands, and forests

High:

- Alluvial plains, floodplains, streams, arroyos
- Mountain ridges, rock outcrops, escarpments
- Grasslands and woodlands with deep soils and of high biodiversity

Very High:

- Stream corridors, riparian areas, floodplains, and wetlands
- Major archaeological sites
- A few rock outcrops and escarpments

The remaining areas on the map are either of low conservation value, are developed (altered by humans), or are excluded from the analysis due to serious data shortages or methodological shortcomings.

Spatial relationships (proximity of an area to existing protected open space; size or shape; landscape context; contiguity with other priority areas; proximity with/contiguity with buffer areas or working lands) were not taken into consideration in the GIS modeling exercise. However, they were taken into consideration in the final analysis for the Green Infrastructure Plan (see below). Model users are free to apply their own interpretation of the landscape's spatial relationships when adapting the GIS model output for their own purposes. In the following sections, an analysis of the spatial context of the GIS output—e.g., regional context, landscape contiguity, the presence of buffer zones, the location of working lands, and recreational uses of the land—helps us propose a Green Infrastructure Plan for the Galisteo Watershed.

A Regional Perspective

The southwestern states of New Mexico, Arizona, and Utah and the southern Rocky Mountains of Colorado and New Mexico form the regional context of the Green Infrastructure Plan. In this context, the Galisteo Basin serves as an ecological corridor of four ecoregions with specific landscape types and their associated geomorphology, hydrology, vegetation associations, and wildlife habitat (New Mexico Department of Game and Fish, 2006). Additionally, at this regional level, the watershed serves as a linkage area of hydrological relationships. It overlaps with the southern part of the Española



Developed areas such as highways and towns were not included in the analysis.

Basin and the northern part of the Estancia Basin, each with separate groundwater characteristics and flow patterns. The predominant surface water and groundwater flow patterns within the watershed area are directed from northeast to southwest, connecting the Southern Rockies ecoregion and western side of the Southwestern Tablelands ecoregion with the Rio Grande delta in the New Mexico-Arizona Plateau ecoregion (see Map 1.1, Ecoregions of the Galisteo Basin).



*Pronghorn rely on the Basin's open grassland habitats.
(Photo: J.R. Douglass)*

Regionally, the Galisteo watershed serves as a wildlife linkage area—for cougar, black bear, mule deer, and potentially elk—between the Southern Rockies Wildlands Network and the area encompassed by the New Mexico Highlands Wildlands Vision (Benedict & Bjornlund, 2002). The Southern Rockies Wildlands Network and the New Mexico Highlands Wildlands Vision are two prominent regional green infrastructure planning initiatives that have been developed in the past by consortia of national experts and organizations concerned with conservation biology. Galisteo Creek and its tributaries form a functional wildlife corridor network that establishes the linkage between the ecoregions. Additionally, the surface water drainage system also forms a regional and local hub of water resources and water-related ecosystems of riparian zones and wetlands in an otherwise arid landscape. The riparian and wetlands system of the watershed serves in particular as a small stepping stone (i.e., an “island”) for waterfowl and other migratory birds that follow the alternative eastern fly routes parallel to the Rio Grande.

At the scale of the southwestern U.S., the Galisteo Basin is an important hub of cultural and archaeological resources, consisting of many prehistoric Native American sites, dating from the 8th to the 17th centuries, and of historical—and historic—Hispanic agricultural settlements and mining districts. The watershed area is also of importance to many of today's Southwestern Pueblo Indian tribes both as ancestral heritage land and as a travel corridor between historic and contemporary settlements. The federal government recognized and protected the prehistoric Native American archaeological value of the watershed in the Galisteo Basin Archaeological Sites Protection Act (S.210, H.R.506) of March 19, 2004 (U.S. Bureau of Land Management, 2004). The Act specifically seeks protection for 24 sites of immense prehistoric significance, including several large pueblo ruins and petroglyph sites. Implementation of the act currently resides with the state office of the BLM in New Mexico. The 24 protected sites are the best examples among thousands of other sites scattered throughout the watershed.

The watershed is also a regional hub of scenic values due to its spectacular views and vistas, its dark night skies offering rare opportunities for horizon-to-horizon star viewing, its imposing and extraordinary



Puebloan pottery sherds at a Basin site

geologic features, and the ecological, cultural, and historical treasures previously described. The watershed's cultural or anthropogenic landscape is supported by the ecological watershed ecosystem. This multilayered landscape can be "read" or interpreted relatively easily by both professional experts and visitors. As such, the watershed has great potential as a destination for ecotourism and cultural heritage tourism. The State Highway 14 corridor, also called the Turquoise Trail Scenic Byway, runs north-south through the western part of the watershed and already serves as a regional tourism corridor between Albuquerque and Santa Fe. Additionally, other basin highways, although not designated as scenic or tourist routes, provide spectacular views and interesting stopping points, as does Amtrak service along the State of New Mexico-owned rail line across the Galisteo Basin, which stops in Lamy.

Landscape Contiguity: Green Infrastructure Hubs and Links in the Galisteo Basin

Nearly the entire Galisteo Basin should be considered a landscape of significant conservation value. Nearly every part of the landscape has outstanding scenic values ("viewshed" qualities) and/or archaeological and historic values. The watershed's network of streams and wetland areas constitutes locally valuable water resources and stands in stark contrast with the dry uplands.

The watershed's central core area is a largely contiguous landscape. However, scattered private homes, rural (county) roads, two state highways (14 and 41), and two federal highways (I-25 and U.S. Route 285) traverse the watershed and create a certain amount of fragmentation from a visual and ecological point of view. The components of the Basin's green infrastructure are in a relatively good state, but are under pressure from water extraction, soil erosion, property fragmentation, road and home construction, potential mineral extraction and oil and gas exploration, and gradual destruction and weathering of cultural resources.

Many spectacular, unobstructed viewlines remain throughout the watershed. Watershed entry points on major highways and county roads still provide a distinct impression of entering a large basin landscape that creates a unique and indelible sense of place. These landscape features also create a clear sense of separation between Santa Fe and the urbanized I-40 corridor south of the Galisteo Basin. Yet, while the current road system allows for relatively easy north-south access, east-west connections in the watershed are poorly developed. The quality of ecotourism and heritage tourism potentially could be enhanced if east-west road connections were improved.

The watershed's most important open space hub is the large open "bowl" in its center, comprising approximately 150,000 acres. (See Map: "Hub" Landscapes of the Galisteo Basin.) This basin is bounded on the north and northeast by Lamy Hill and its escarpments, by the Cerrillos Hills to the west, on the east by the mesa escarpment that runs south-southeast from the village of Lamy, and on the south by the rise toward the Estancia Basin and the piedmont and escarpment of the Ortiz Mountains.

“Hub” Landscapes of the Galisteo Basin

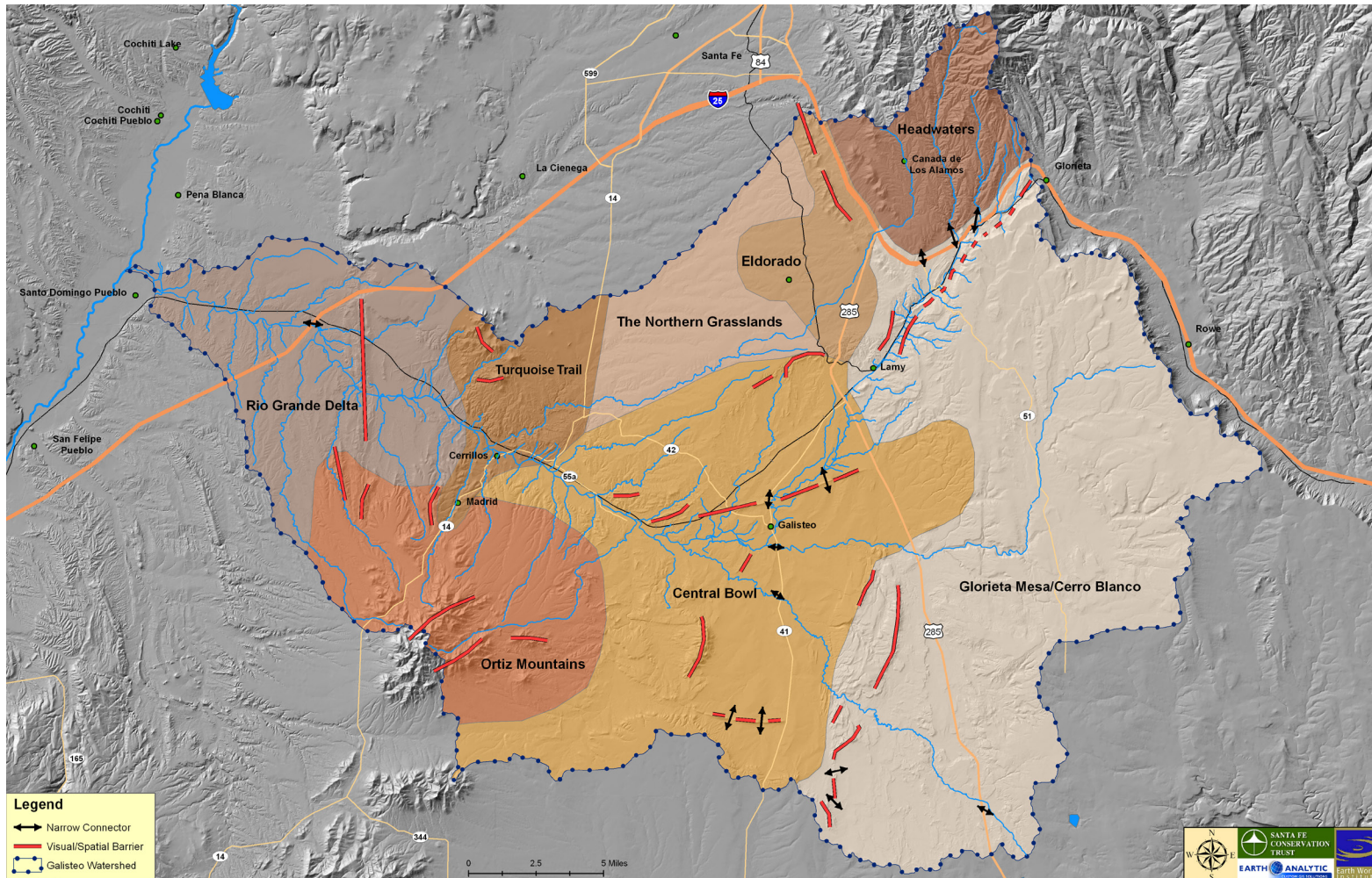

This hub encompasses the watershed’s most important scenic values (including sweeping, 360 degree views from high points), wildlife habitat (grassland habitat for pronghorn and woodland and canyon habitat for deer and cougar), the central riparian and wetland network of the watershed, and the most important cultural and historical sites. Additionally, the landscape includes several large, contiguous ranches. However, highways and fences create the most important barriers to wildlife mobility in this part of the Basin.

There are several secondary large open-space hubs in the watershed: National Forest lands in the Galisteo Creek headwaters (30,000 acres); the forest and woodlands of Glorieta/Rowe Mesa, along with the eastern half of San Cristobal Ranch (total about 150,000 acres); 15,000 acres of grasslands owned by the State Land Office and the Rancho Viejo Partners and located northwest of the Galisteo Basin Preserve; the Ortiz Mountain area; and the Galisteo Creek delta below La Bajada and crossing Santo Domingo Pueblo. From a land use perspective, the portion of the Turquoise Trail National Scenic Byway corridor running from the San Marcos area to Golden can also be considered a secondary open-space hub.

These large-scale hubs are connected via various linkages, most particularly the stream corridors of Galisteo Creek and its tributaries, broad saddles in the landscape, escarpments, and sometimes narrow passages in escarpments and volcanic dikes. Several of these corridors are fragmented by exurban development (scattered homes and so-called ranchettes—parcels of up to 1,000 acres with a few buildings surrounded by pasture and/or rangeland), transportation lines (roads and railroads), steeply rising geologic features, or a combination of these factors.

The large-scale hubs can be subdivided into smaller-scale hubs and corridors from an ecological, scenic, cultural/historical, and/or hydrological perspective. Just as with large-scale hubs, these smaller hubs are linked via corridors, frequently experiencing partial separation or fragmentation from development, roads, and geologic features.

Wildlife Populations and Habitat Contiguity: Hubs and Links for Wildlife

The watershed includes valuable wildlife habitat, which is concentrated in the stream network and its linkages with open grasslands and mountainous woodlands and forests. However, wildlife habitat in the watershed is poorly studied, documented, and understood, even by experts.

Some important ecological communities that maintain a broad diversity of wildlife remain relatively intact within the Galisteo Basin. Search results from the Biota Information System of New Mexico (BISON-M, 2007) indicate that 285 species of vertebrates have known or expected occurrence within the Galisteo Basin portion of Santa Fe County. BISON-M database queries by GAP vegetation type that most closely matched vegetation within the Galisteo Basin produced the following numbers of vertebrate species by type: Short-Grass Steppe 175 species; Lowland Riparian 223 species; Piñon-Juniper and Juniper Savanna 220 species; Ponderosa Pine 169 species. Search results included 24 species with a federal or state status of Endangered, Threatened, Candidate (or under investigation for listing), or Species of Concern/Sensitive. These special-status species, including some specific factors related to the conservation of these species, are listed in Appendix I.

Black bear, cougar, bobcat, coyote, foxes (gray, red, and kit), weasels, and badger comprise most of the mammalian predators, while herbivorous mammals include mule deer, pronghorn, elk, and many rodent species. Native game birds including waterfowl and mourning doves are regularly present. Large terrestrial mammals, especially carnivores, are often used as “umbrella species” for conservation planning because they are wide-ranging and require large blocks of connected habitats, which also serve to meet the needs of many other wildlife species. In 2008, the New Mexico Department of Game and Fish financed a project to evaluate important habitat linkages using cougar as an umbrella species. The study was completed by Kurt Menke of Bird’s Eye View and resulted in a map that identifies three major pathways from the Ortiz Mountains to the Sangre de Cristo Mountains across the Galisteo Basin. The pathways largely follow the San Marcos Arroyo and Cañada de los Alamos, and the Galisteo Creek.

Cougars require rough terrain including canyons, cliffs, arroyos and dense piñon/juniper woodlands. Such landscapes are found in the upper Galisteo Creek canyon near Upper Cañoncito, on parts of Glorieta Mesa, on Cerro Pelon and Cerro Blanco (White Bluffs), in the cliffs and escarpments on the north and south side of Galisteo Creek, and on the flanks of Ortiz Mountain. Cougar habitat overlaps largely with mule deer habitat, which is comprised of a combination of hillsides and open areas between piñon-juniper woodland. Mule deer in this area utilize grasslands in the spring and summer and woodlands for browse in the fall and winter (Johnson & Smith, 2005). Cougar and black bear predation of domesticated

animals and nuisance complaints increase as urban and exurban areas expand and move further into mountainous or other “wild” areas. The increasing demand for resolution of conflicts between domestic animals and predators, which may involve lethal removal of species such as cougars, can jeopardize the ability of these predators to continue to serve their ecological role within these local wildland-urban interface areas.



Predators found in the Basin include bobcat (shown here), black bear, cougar, fox, and coyote.

Residences are increasingly being built in ecotones—ecological transition zones—between rocky woodlands and open grassy plains. Unfortunately, ecotones serve as prime wildlife habitat. For example, the grasslands are vital to pronghorn, which require open rangeland with access to water sources within four miles. The greatest barriers to maintaining viable pronghorn habitat in the watershed is landscape fragmentation due to geologic features, roads, residential development, and fences (pronghorn cannot jump fences) (Johnson & Smith, 2005).

Additionally, aquatic and riparian habitats in New Mexico are important yet vulnerable habitats for a diversity of wildlife. Information within BISON-M indicates that even when excluding fishes, over 70% of vertebrates reliably occurring in New Mexico utilize aquatic, semi-aquatic or riparian habitats during one or all of their life stages. Over the past 150 years wetland acreage in the Galisteo Basin has gradually dwindled from about 5,000 acres to about 1,000 acres, reducing habitat for water-dependent plants and animals (Vrooman, 2006).

The Comprehensive Wildlife Conservation Strategy (CWCS) for New Mexico (New Mexico Department of Game and Fish, 2006) provides an in-depth overview of conservation needs and strategies for wildlife for the various New Mexico ecoregions and key ecological habitats, such as riparian and wetland habitats. The CWCS synthesis of conservation priorities and an overview of key areas for conservation action suggest that the riparian zone of the Galisteo Watershed west of the Village of Galisteo (in the Central Bowl hub) has the highest wildlife conservation priority, as shown in Table 3.1, in terms of its synergistic effects of factors that influence habitat. Additionally, the ridges and mountain outcrops show a medium-high priority. These CWCS prioritizations support the findings of the present (GWCI) study. The Southern Rocky Mountain ecoregion (Sangre de Cristo Mountains) and the Glorieta Mesa area, however, are indicated as the top-priority areas to assess for conservation efforts.

Table 3.1 Summary Data: The Central Bowl

The Central Bowl (in New Mexico/Arizona Plateau Ecoregion); see Map 3.1
Sub-Areas
Galisteo Basin Preserve; northwestern and western grasslands of San Cristobal Ranch; Saddleback Ranch; Cerro Pelon Ranch; northern part of Zorro Ranch; northern part of Lone Mountain Ranch; central historical, alluvial floodplain; canyonlands between CR 42 and Galisteo Creek.
Links:
The sub-areas are well connected through the drainage system in the landscape as well as through contiguity of their boundaries. Gaps in volcanic dikes--including El Puertocito (east of Galisteo), the Galisteo Creek gap north of the Village of Galisteo, and Comanche Gap in a volcanic dike on the Zorro Ranch south of Galisteo--connect open grasslands and provide key pronghorn migration routes. Dike gaps are also significant for the prehistoric petroglyphs found along their walls as well as for the visual experience afforded by their window-like framing of viewlines.
Land Use, Ownership and Current Conservation Measures:
Predominantly private ranch land with scattered parcels managed by the State Land Office, BLM or Santa Fe County Open Space. Low impact cattle ranching, horse grazing, or non-agricultural use.
Film industry (Cerro Pelon Ranch movie set)
Localized outdoor recreation (mostly horseback riding)
Residential development (Galisteo, CR 42, CR55-A/B/C); will increase with Trenza and development of Saddleback Ranch, Cash Ranch, and other sites.
At least twenty conservation easements, protecting over 200 acres, currently exist in the Central Bowl, as well as additional easements on major archaeological sites.
Conservation threats and problems:
Gradual development around the Village of Galisteo and other properties
Potential of increased light pollution from planned expansion of the Cerro Pelon Ranch movie set
Highway 41 widening and fencing; pronghorn barriers
Dewatering through overuse of groundwater and surface water
Degradation and potential collapse of the old dam in Galisteo Creek on Cerro Pelon Ranch
Oil and gas exploration in the alluvial bottomlands
Runoff from developed areas
Conservation and Restoration priorities:
Conserve ridges and hills around Lamy and on the northern rim of Galisteo Basin Preserve
Conserve the volcanic and sandstone outcrops and canyon lands between Cerrillos and Galisteo
Conserve Galisteo Creek corridor from Lamy to Cerrillos, especially its wetlands, riparian areas, and alluvial plain and all major tributaries (arroyos) draining into the Galisteo Creek
Conserve the San Cristobal Creek and associated archaeological sites
Conserve the Arroyo Chorro and associated archaeological sites (e.g. San Lazaro Pueblo)
Conserve Burnt Corn Pueblo area and associated arroyos, canyons and hills
Conserve the eastern flanks of Ortiz Mountain (upper Arroyo Chorro, Lone Mountain Ranch)
San Marcos Arroyo drainage and wetlands and the San Marcos Pueblo site
Creation of buffer zone along the creek and along all tributaries

Erosion control (runoff control and revegetation) in all major drainages
Resetting of fences for pronghorn migration; restoration of grasslands
Maintaining the viewsheds from all entry points and high points
Further research needed:
Wildlife movement and migration patterns
Threatened and endangered species surveys

Map 3.1: Central Bowl

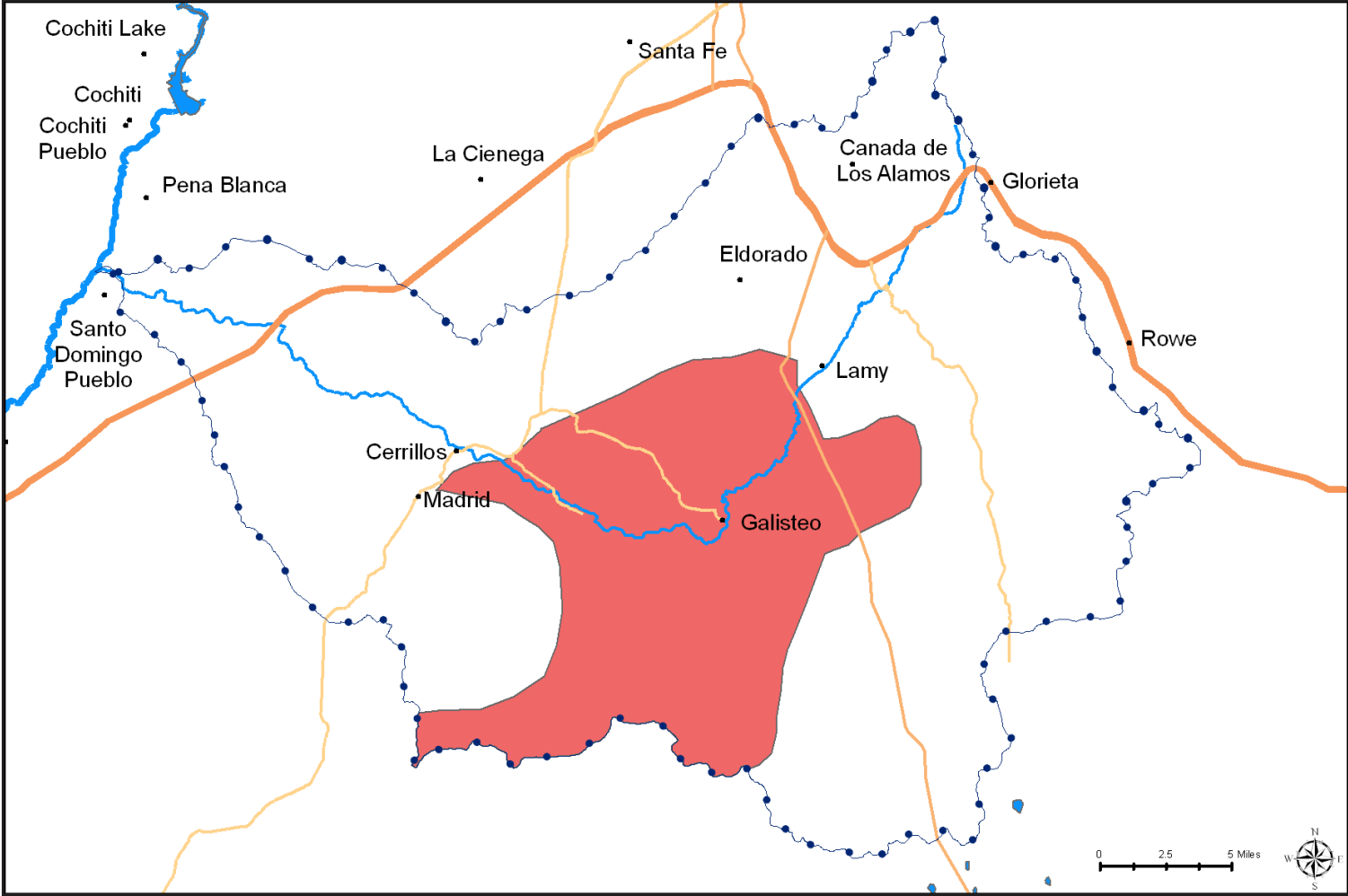

Table 3.2 Summary Data: Galisteo Creek Headwaters and Forest Lands

Galisteo Creek Headwaters and Forest Lands (in Southern Rockies Ecoregion); see Map 3.2
Sub-Areas
Galisteo Creek headwaters (Apache Canyon, Deer Creek, Galisteo Creek) Cañada de los Alamos drainage
Links:
These two sub-areas are connected by a ridgeline. US Forest Service Road 79 runs over the ridge. The ridgeline and road probably do not form a major barrier for wildlife. However, the entire Headwaters and Forest lands hub is severely disconnected from Glorieta Mesa and the landscape to the south and southwest due to the I-25 corridor, Old Las Vegas Highway, and associated residential development. Box culverts under the freeway connect the headwaters streams to Galisteo Creek proper. These stream connections are the only viable linkages between the headwaters and the rest of the watershed.
Land Use, Ownership, and Current Conservation Measures:
Two-thirds of the area is National Forest land. The lower one-third is privately owned. There is a rather large private grazing allotment in the area. Most of the National Forest land is roadless and used for low-impact outdoor recreation. However, (illegal) four-wheel off-road vehicle use causes some disturbance. Fire hazard causes a potential threat to the landscape. The southern rim and southeastern fringe area is used for private, residential and small business use. Dense woodland and forested areas provide significant cover for wildlife throughout the area. Two conservation easements covering 78 acres are found within this hub.
Conservation threats and problems:
Isolation by the I-25 corridor Catastrophic wildfire hazard Residential development
Conservation and Restoration priorities:
Conserve Apache Canyon's and Cañada de los Alamos' stream bottoms and wetlands. The roadless forestland landscape Private forest lands Wetlands, springs and stream bottoms
Further research needed:
Wildlife movement and migration patterns Threatened and endangered species surveys

Map 3.2: Galisteo Creek Headwaters

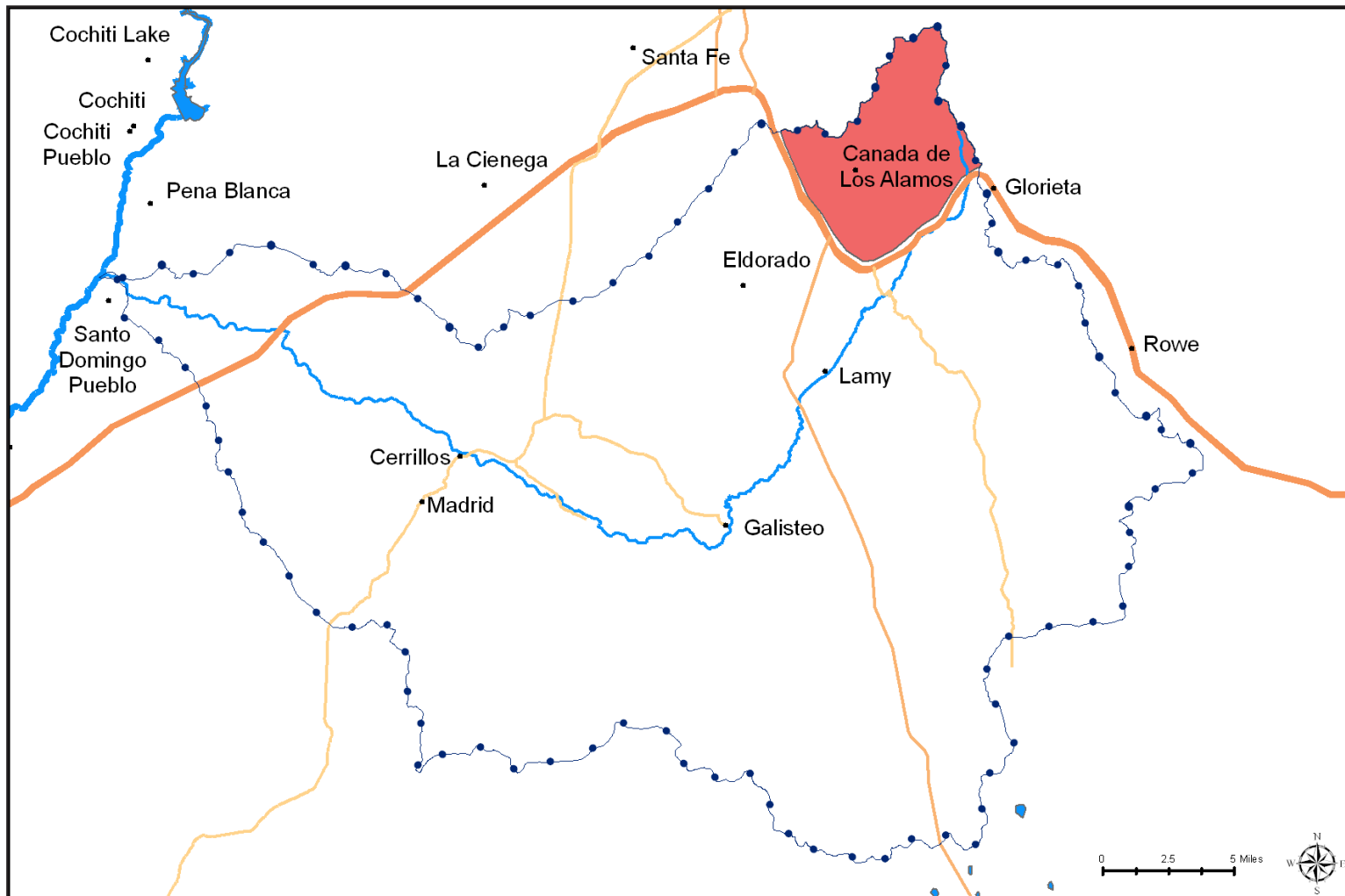

Table 3.3 Summary Data: Glorieta/Rowe Mesa and Cerro Blanco (White Bluffs)

Glorieta/Rowe Mesa and Cerro Blanco (White Bluffs) (in Southwestern Tablelands Ecoregion); see Map 3.3
Sub-Areas
National Forest lands on the eastern side of Glorieta/Rowe Mesa
Private lands on the western side of the Mesa, Padre Springs, Ojo de la Vaca, Arroyo Salado, eastern San Cristobal Arroyo
Mesa slopes and eastern San Cristobal Ranch
Links:
Arroyos and grassy valleys
Contiguous woodlands
Land Use, Ownership and Current Conservation Measures:
Significant acreage in the Santa Fe National Forest, used for harvesting of firewood and various non-timber forest products, grazing and local recreational activities
Scattered parcels managed by the State Land Office and BLM, used for grazing
Two very large ranches with active cattle operations (San Cristobal Ranch and Canyon Blanco Ranch), several smaller ranches, and a CSA farm: Beneficial Farm & Ranch (Community-Supported Agriculture)
Small residential lots in the Ojo de la Vaca area, Valencia, and Upper and Lower Cañoncito
Highway 285 corridor (undeveloped), crossing San Cristobal Ranch
Eldorado Wilderness open space area in the northwestern corner of the hub (Lower Cañoncito)
474 acres in two conservation easements held by the Santa Fe Conservation Trust
Conservation threats and problems:
Highway 285 widening
Gradual development of Ojo de la Vaca; proposed paving of county roads
Ranch divestment and fragmentation
Conservation and Restoration priorities:
Conserve San Cristobal Arroyo and associated pueblo ruin sites
Conserve Arroyo de la Jara and associated pueblo ruin sites
Conserve stream bottoms, springs and alluvial plains and archaeological sites associated with the Arroyo Salado and Ojo de la Vaca
Forest restoration planning and implementation with a view to wildfire prevention, soil and water conservation, wildlife habitat improvement, and drainage management on roads and tracks.
Conserve Cerro Blanco range
Conserve Galisteo Creek floodplain, and mountains and canyons around Lamy and Lower Cañoncito Box Canyon area
Highway 285 wildlife crossings
Erosion on Glorieta Mesa, and especially in springs, wetlands, drainages and floodplain areas
Erosion control on archaeological sites
Further research needed:
Data gathering and mapping for southern San Cristobal Ranch
Wildlife movement and migration patterns
Threatened and endangered species surveys

Map 3.3: Glorieta/Rowe Mesa

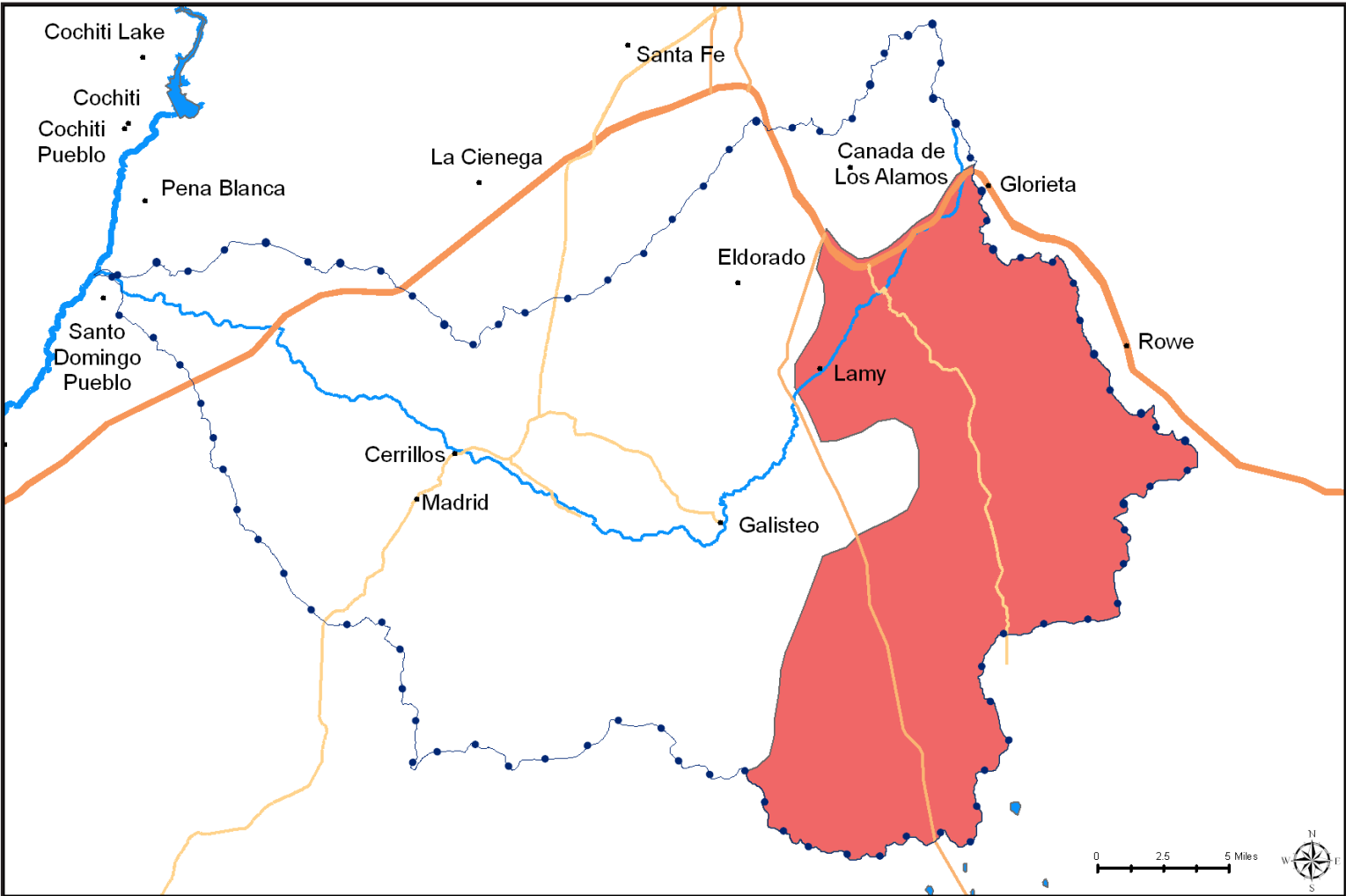

Table 3.4 Summary Data: The Northern Grasslands

The Northern Grasslands (in New Mexico/Arizona Plateau Ecoregion): Map 3.4
Sub-Areas
Grasslands and arroyos west of Sunlit Hills (north of Eldorado)
Grasslands west of Eldorado (Gallina Arroyo drainage area)
Links:
Wildlife corridors through the grasslands on Rancho Viejo lands outside the watershed and arroyo bottoms
Recreational corridor along the Santa Fe Rail Trail
Eldorado greenbelt corridors
State Land Office parcels immediately west of Eldorado
Land Use, Ownership and Current Conservation Measures:
Mostly private land belonging to Rancho Viejo Partners in the north; many private small lots to the south
Rancho Viejo is seeking protection of about 10,000 acres of open space
Scattered residential development in the Silverado neighborhood
Conservation threats and problems:
Ongoing development of the Rancho Viejo property and in the Silverado and Rancho de San Marcos subdivisions
Dewatering due to domestic and community wells and possibly water extraction (diversion) upstream in Eldorado
Fencing designs that block pronghorn migration
Potential overgrazing on State Land Office lands and resulting erosion and invasive weeds; also trail development plans on state land may affect archaeological values and spiritual values of native communities
Conservation and Restoration priorities:
Conserve Gallina Arroyo drainage (floodplain area)
Conserve San Marcos Arroyo drainage and wetlands
Conserve San Marcos Pueblo
Conserve pronghorn habitat
Connection between arroyo landscape north of Eldorado and Gallina Arroyo drainage area west of Eldorado
Protection of Upper San Marcos watershed from erosion
Protection of entire landscape from groundwater extraction that jeopardizes downstream springs and wetlands
Further research needed:
Surface and groundwater flows in relation to wetlands and springs in the Turquoise Trail corridor
Wildlife (pronghorn) movement and migration patterns
Threatened and endangered species surveys

Map 3.4: Northern Grasslands

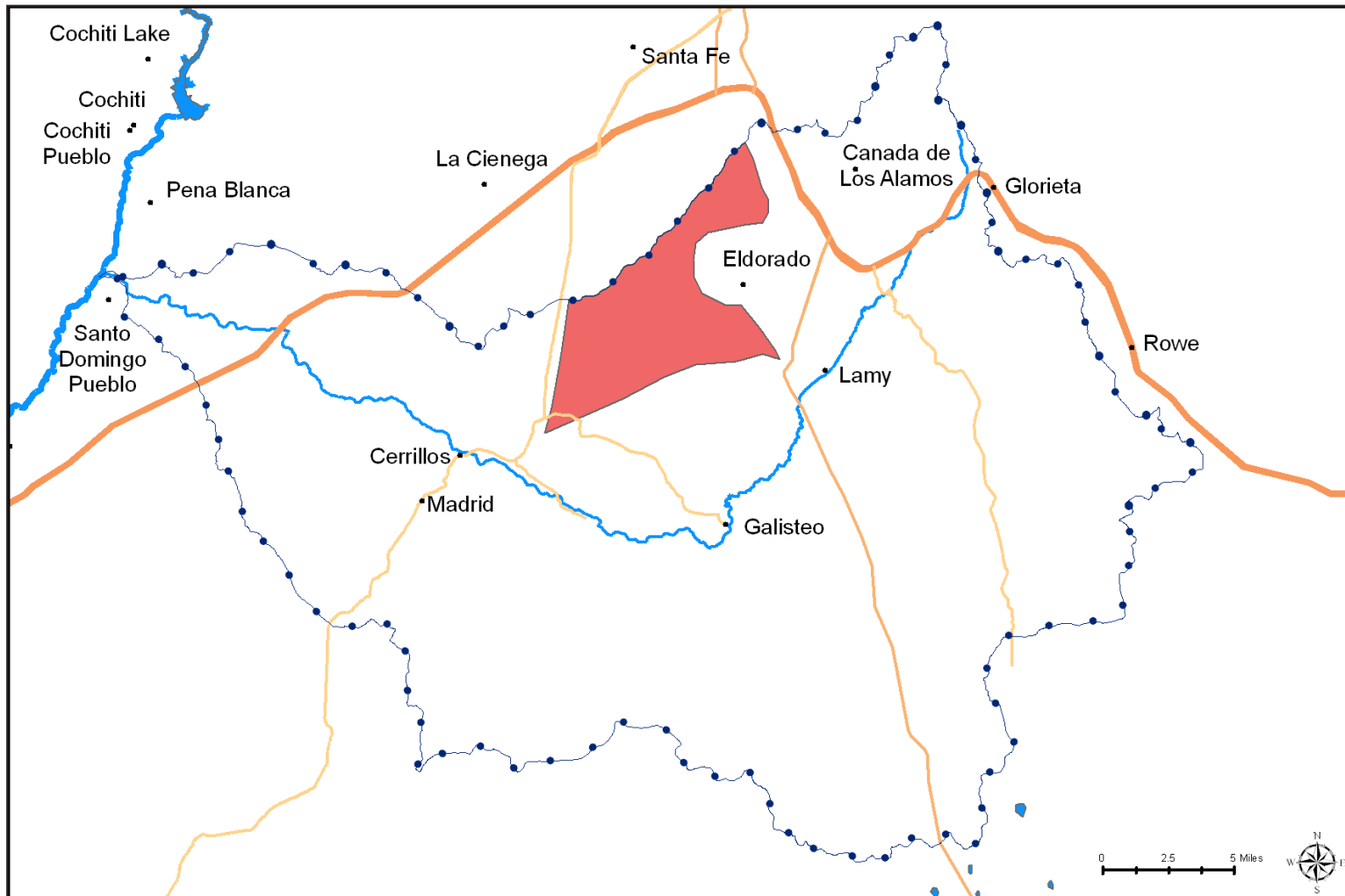

Table 3.5 Summary Data: Ortiz Mountain

Ortiz Mountain (in New Mexico/Arizona Mountains Ecoregion); see Map 3.5
Sub-Areas
Mountain area proper
Northern and northeastern flanks, east of Madrid
Northwestern flanks, west of Madrid
Links:
Links through arroyo bottoms with surrounding landscape
Land Use, Ownership and Current Conservation Measures:
Mostly privately owned by many small residential and commercial owners
Concentration in the Village of Madrid and along CR 55 (Goldmine Road)
Conservation areas on west flank (Ortiz Mountain Ranch, 11,786 acres managed by The Nature Conservancy); mountain top (Ortiz Mountain Preserve, 1,350 acres owned by County Open Space in partnership with the Santa Fe Botanical Garden and SFCT); LAC Minerals mine reclamation site on east flank.
Conservation threats and problems:
Residential development
Possible mining
Conservation and Restoration priorities:
Conserve drainages
Conserve historic downtown Madrid and mining district
Arroyo connections with surrounding landscape
Further research needed:
Wildlife movement and migration patterns
Threatened and endangered species surveys

Map 3.5: Ortiz Mountain

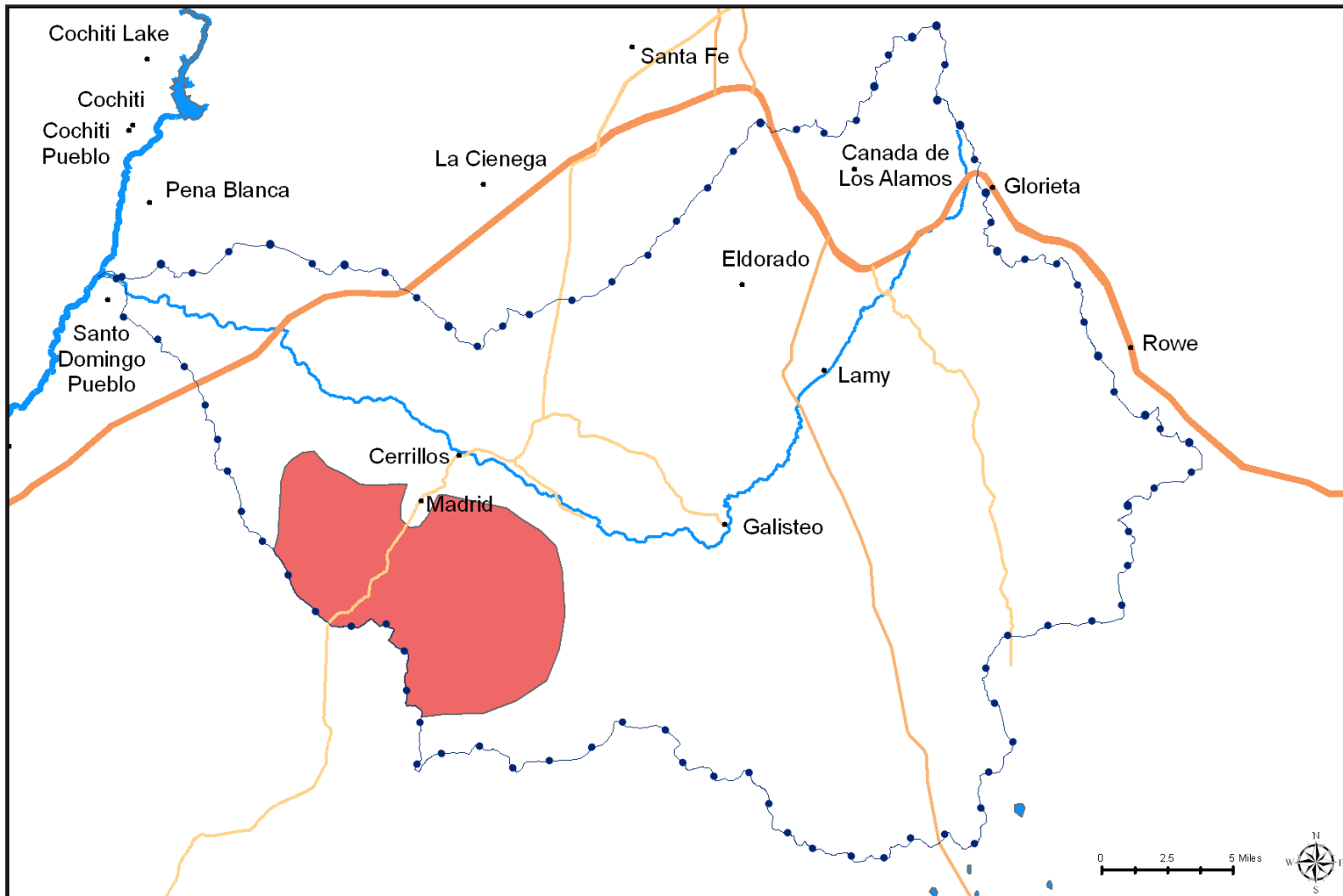

Table 3.6 Summary Data: Rio Grande Delta

Rio Grande Delta (in New Mexico/Arizona Plateau Ecoregion); see Map 3.6
Sub-Areas
La Bajada and Galisteo Dam
Santo Domingo Pueblo
Links:
Via Galisteo Creek and drainages originating on Ortiz Mountain
Land Use, Ownership and Current Conservation Measures:
Mostly private land (many small properties in the Madrid and Waldo area, and one larger ranch)
Some BLM and Forest Service parcels on La Bajada
Kewa Pueblo (formerly known as Santo Domingo Pueblo)
Army Corps of Engineers manages the Galisteo Dam area (about 2,900 acres)
There is one 40-acre conservation easement in this hub
Conservation threats and problems:
Ongoing development near Madrid; proposed development on various private properties north and west of the Galisteo dam
Proposed mining activities
Conservation and Restoration priorities:
Conserve Galisteo Creek floodplain and wetlands and tributaries
Conserve La Bajada watershed
Further research needed:
Wildlife movement and migration patterns
Threatened and endangered species surveys

Map 3.6: Rio Grande Delta

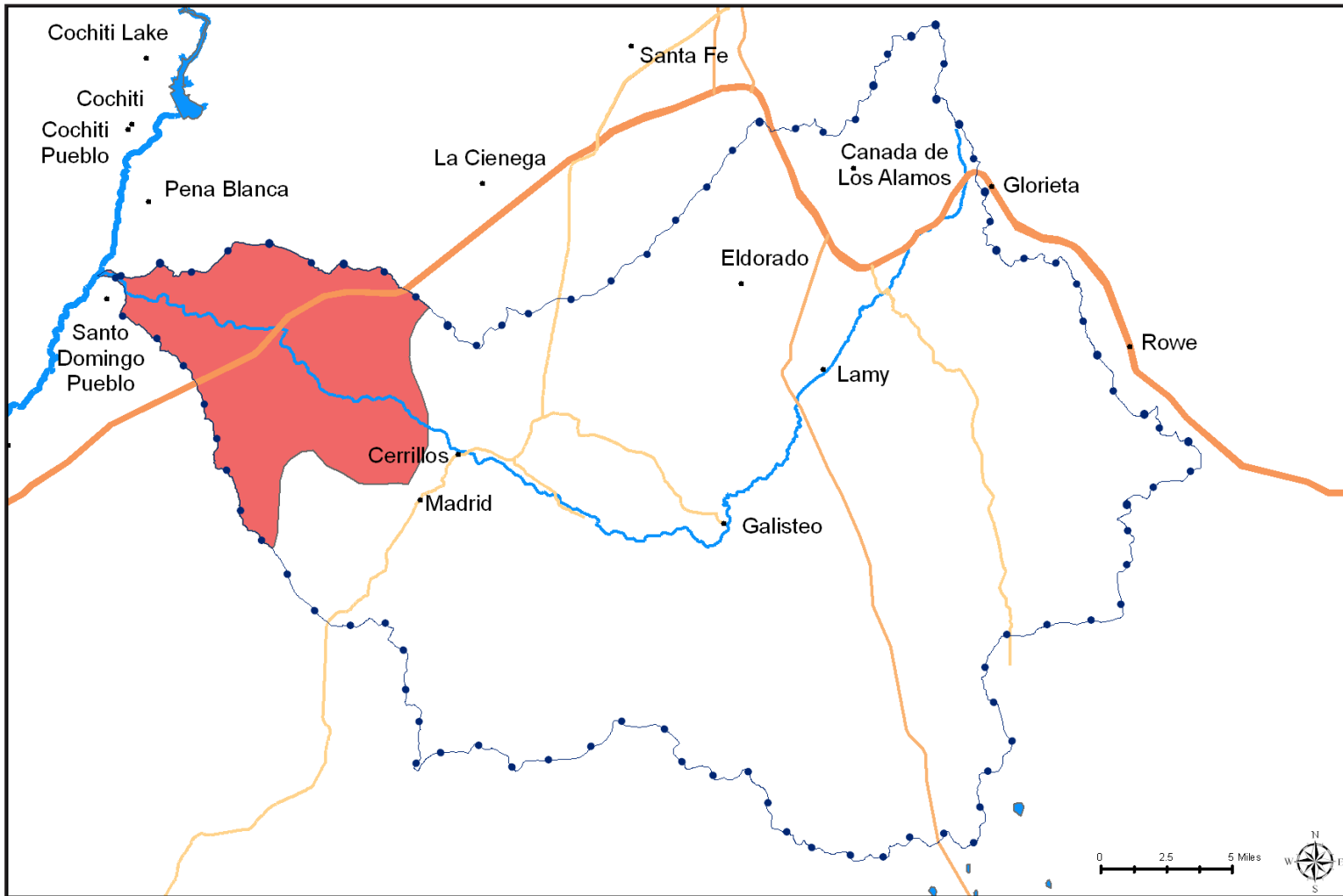
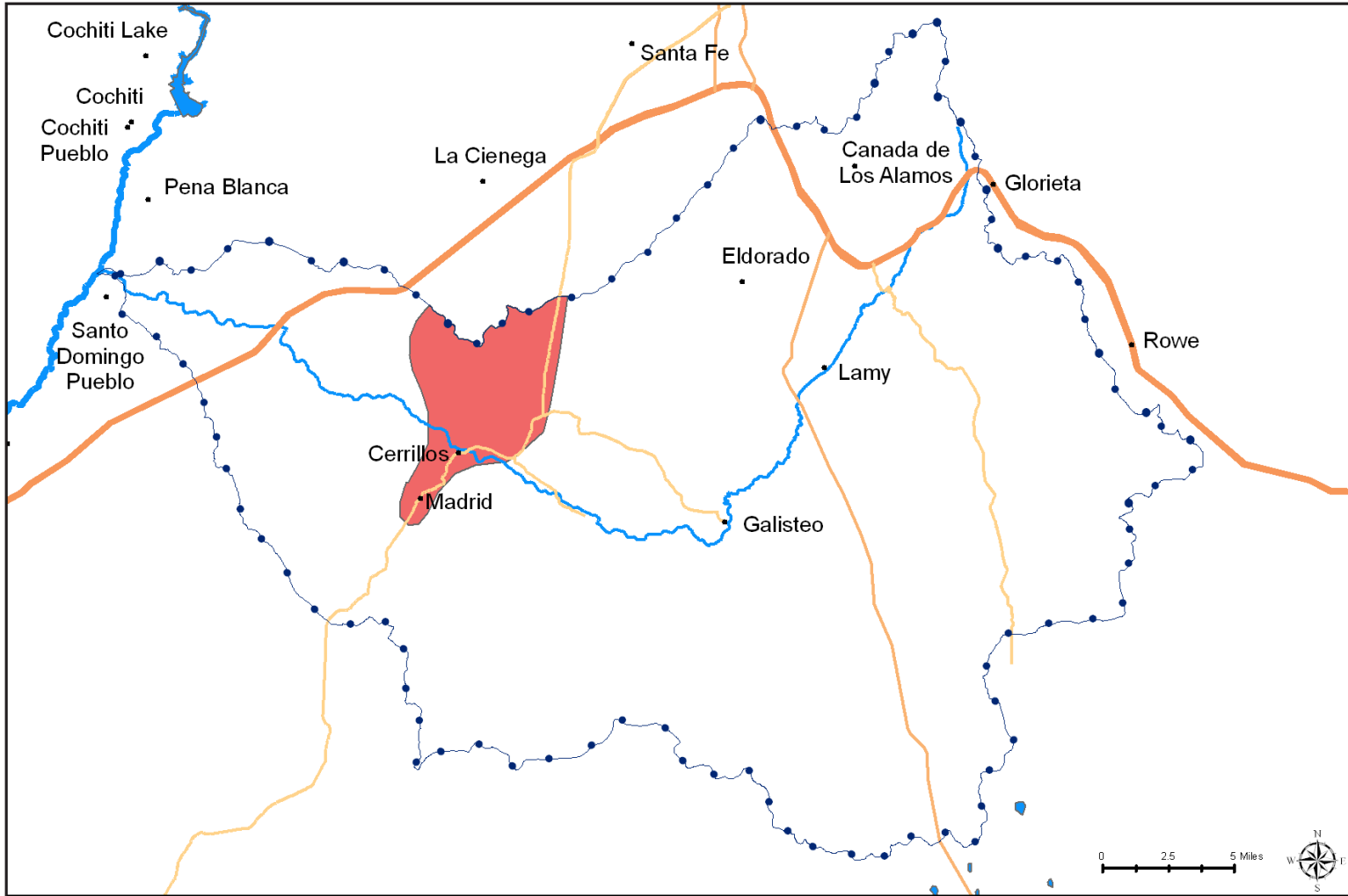

Table 3.7 Summary Data: The Turquoise Trail

The Turquoise Trail (in New Mexico/Arizona Plateau Ecoregion); see Map 3.7
Sub-Areas
San-Marcos District, Village of Cerrillos, and Cerrillos Hills
Madrid Village area
Links:
Highway 14 connections
Waldo Road (I-25 connection)
Land Use, Ownership and Current Conservation Measures:
Private residences and businesses
Film industry (Eaves movie ranch)
Many private horse riding operations and horse health center
Cerrillos Hills State Park (owned by Santa Fe County Open Space and Trails) and adjacent parcels in Cerrillos Hills managed by BLM and State Land Office
Conservation easements on San Marcos Pueblo, and along Highway 14 near Cerrillos, a conservation easement to SFCT (126 acres)
County Open Space in Madrid and the Ortiz Mountain Preserve (Rio Grande Delta Hub)
Conservation threats and problems:
Residential development
Potential impacts of rapidly growing heritage tourism and ecotourism
Well water shortages and drying up of wetlands due to groundwater extraction in the eastern parts of the Galisteo Watershed
Conservation and Restoration priorities:
Conserve San Marcos Arroyo and Galisteo Creek floodplain and wetlands
Conserve Major tributaries
Conserve Cerrillos Hills
Conserve Madrid Historic Mining District
San Marcos Arroyo and Galisteo Creek wetlands
Further research needed:
Groundwater extraction impact on wetlands, springs and streams

Map 3.7: Turquoise Trail



Corridors and Buffer Zones

Ridgelines and watercourses such as Galisteo Creek and its tributaries form the most important corridors in the Green Infrastructure network. The GIS analysis revealed these linkage zones as highest-priority areas for conservation in the watershed. However, in several locations, these linkages are severely constricted or obstructed. Besides conservation of the functioning linkage zones, efforts will need to be made to restore and enhance the corridor functions and/or mitigate the barriers, particularly highways and highway fences. Additional gaps and barriers are caused by scattered residential development, especially in ecotones and along stream corridors.

Needed restoration efforts for this corridor include:

- Modification of fences to accommodate the movement of pronghorn between different grasslands
- Traffic indications (signs) that caution motorists about wildlife crossing areas
- Widening of culverts in wildlife crossing zones to serve as physical corridors
- Construction of wildlife passages (especially across I-25 in the Cañoncito-Valencia-Glorieta area)
- Restoration of contiguous zones of vegetation in low-lying land between home sites in residential areas located in ecotones to provide cover for wildlife



Fences in the Basin create barriers for movement of wildlife, particularly pronghorn.

Connecting corridors can also be protected by creating buffer zones along stream corridors and at confluences of arroyos. Acting as natural sponges, riparian buffer zones serve to reduce stormwater runoff concentrations from developed areas. Absorbing water and releasing it slowly over time, buffers lower peak flood flows, recharge groundwater, purify runoff, and provide a protective cushion of habitat for wildlife. Additionally, the buffer zones enhance the visual quality of the stream system. Buffer zones can also be applied along wildlife corridors in the grasslands, especially around volcanic dike gaps, rocky escarpments, and highway crossing zones.

Buffer zones should be established for tributaries in headwaters areas that are becoming severely eroded by headcuts (a sudden change in elevation at the upstream edge of a channel). Such badlands tend to occur also at the foot of large alluvial fans and perching meadows (see Appendix A). These areas should

be managed carefully to reduce any further soil erosion. By establishing buffer zones across such deteriorated landscapes, these areas may over time serve as corridors between adjacent conservation areas and associated stream systems. Buffer zones may also serve to retain sediment, control erosion, mitigate water pollution, reduce weed dispersal, block inappropriate human access, encourage wildlife mobility, absorb flood flows, slow advancing wildfires, provide shelter from wind, and enhance microclimates.

Viewshed corridors should be kept undisturbed across the central part of the watershed. The view lines (or fans) are particularly oriented from north to south and vice versa from vantage points along the major highways entering the watershed, as well as from higher elevations within Santa Fe and the Sangre de Cristo Mountains. Pristine views play an important economic role in the area, as they form an attraction for tourism and serve as open-space backdrops for commercial movie ranches in the watershed.

Conservation Initiatives

A considerable acreage of private and public land in the Galisteo Basin is being managed for conservation purposes or for purposes that have until the present implicitly resulted in the conservation of open space and natural resources. These lands include most of the private properties in the central and southern part of the watershed, such as the Eldorado Community Preserve, the Galisteo Basin Preserve (from Thornton Ranch), Three-Horse Ranch, La Jara Ranch, San Cristobal Ranch, Cerro Pelon Ranch, Zorro Ranch, Lone Mountain Ranch, the LAC Minerals gold mine reclamation site on Ortiz Mountain, and the Ortiz Mountain Ranch. Most of these properties also include leases on adjacent lands managed by the BLM and State Land Office. Several properties also are connected to lands managed by Santa Fe County's Open Space and Trails Division. Some properties include conservation easements. The total acreage of these de facto conservation areas exceeds 170,000 acres, or one-third of the entire Galisteo Basin area, and constitutes a mostly contiguous area ranging from Lower Cañoncito and Glorieta Mesa to Ortiz Mountain. The contiguity of this area is locally being interrupted (fragmented) by state and federal highways, scattered exurban development, and concentrated development around the Village of Galisteo.



The Galisteo Basin is probably best known for its spectacular views



Ranching has long been a tradition in the Basin.

Working Lands

There are a few active ranches and farms in the watershed that constitute hubs of working lands. These include the San Cristobal Ranch, Beneficial Farm & Ranch, the portions of the Canyon Blanco Ranch found on Glorieta/Rowe Mesa, portions of Cerro Pelon Ranch, portions of Thompson Ranch, and Bonanza Creek Ranch (north of the Cerrillos Hills). Additionally, SunStar Herbs and other small farming operations occur west of Madrid, south of Galisteo Reservoir, and on the northern flanks of Ortiz Mountain. Working lands also include the commercial movie sets on the Cerro Pelon Ranch south of Galisteo and the Eaves Movie Ranch in Lone Butte, north of Cerrillos.

Recreation Hubs

Recreation hubs include National Forest lands in the headwaters and on Glorieta Mesa, the Galisteo Basin Preserve, and potentially the adjacent State Land Office parcels and BLM parcels in the Central Bowl of the watershed, as well as the Cerrillos Hills State Park and the Ortiz Mountain Preserve and surrounding public lands. Potential recreation uses include a regional non-motorized trail system linking local trails countywide.

Consequences of Residential and Commercial Development

The current pattern of residential development shows concentrations in the I-25 corridor between Sunlit Hills and Glorieta, in and around Eldorado, in Lower Cañoncito, on Glorieta Mesa (Ojo de la Vaca), around Galisteo, along County Roads 42 and 55-A, in the San Marcos District, along Goldmine Road (CR 55), in the Cerrillos-Madrid corridor, along Mailbox Road (west of Madrid), and in Santo Domingo Pueblo. Commercial development is very limited throughout the watershed.

Future development is to be expected to the south and northwest of Eldorado, west and south of Lamy (Galisteo Basin Preserve and northern part of Saddleback Ranch, respectively), in Ojo de la Vaca, on the west side of Galisteo, along County Road 55-A, on the Bonanza Creek Ranch, and perhaps west of Cerrillos and in the I-25 corridor between La Bajada and Santo Domingo Pueblo.



The Basin's trails provide a recreational resource for the public.

Based on the previous analysis of preferred open space areas, care should be taken to avoid development in prime conservation areas, such as the river corridor and buffer zones, gaps in volcanic dikes, areas immediately below visual entry points in the watershed, on crests and heights, and in the I-25 corridor from Cañoncito to Glorieta. Additionally, development should be sparse or avoided in rugged transition zones from woodlands to grasslands. These edges of the landscape are important wildlife habitat and migration corridors for large predators, which are essential to ecosystem health.

Anticipated Effects of Climate Change

Climate change will most likely cause higher temperatures and evaporation rates. These factors will probably lead to sparser vegetation in the lower grasslands and woodlands with a corresponding increase in sheet and gully erosion rates. Forested habitat will shrink to higher elevations. Wildlife will move with habitat changes. Fewer open water sources will be available, which will increase the stress on wildlife.

It will be important to consider alluvial fans and flood-prone areas as prime open space to allow water to run freely and avoid flood damage to buildings, built infrastructure, and other investments. Winter weather is expected to generate more rain and less snow. This will lead to increased peak runoff regimes, raising flood hazards (as well as sediment transport and deposition) in arroyos, Galisteo Creek, alluvial fans, and other flood-prone areas.

Climate change also means that areas of high biomass, such as woodlands and forests, should be designated as prime open space due to increased fire hazard. The expected hotter and drier conditions will result in increased flammability of such areas after occasional wet years. If the green infrastructure includes such open space areas, land stewardship should focus on reducing fuel loads. In residential areas, defensible space should be created around structures to buffer buildings from fire-prone wildlands.

These observations underscore the importance of the network of streams and wetlands as well as forests, mountains, and ridges as prime, high-priority conservation areas. Additionally, the effects of climate change will increase the need for erosion control and fire-risk reduction on these lands. Given the considerable costs of erosion control and wildfire hazard reduction projects, the feasibility of needed stewardship activities must be weighed against the importance of these areas in the open space network on a case-by-case basis.



Home development in the Basin is on the increase.

Ongoing Planning

Ongoing planning as follow-up to this preliminary Green Infrastructure Plan includes:

1. Public dialogue meetings to fine-tune the Plan and the prioritization strategy.

In the course of 2007 and 2008, the Galisteo Watershed Partnership, with guidance from Santa Fe County, Santa Fe Conservation Trust, and Earth Works Institute, organized a series of public dialogue meetings to gather input and clarifications for various aspects of the Green Infrastructure Plan. In February and May 2007, a working group organized public meetings to discuss the County development review process and the opportunities and incentives available for landowners to preserve large contiguous tracts of land in the face of a potential need to divest and subdivide their ranches. Meetings in October and November 2007 focused on water availability and people's preferences for future residential development in and around the Galisteo Basin. A February 2008 meeting addressed people's treasured places in the watershed ("Places of Querencia") in an attempt to provide public confirmation for the Green Infrastructure hubs and corridors and the identified open space treasures in the Green Infrastructure Plan. Finally, in May and June 2008, the GWP convened partners and stakeholders around issues of wildlife habitat and the need to identify corridors and preserves for wildlife conservation purposes in the watershed.

In late 2007, Santa Fe County identified most of the Galisteo Basin as the Galisteo Growth Management Area. Participants at the Fall 2007 meetings of the GWP expressed a need to earmark the Galisteo Basin as an area in Santa Fe County where growth management should focus on dispersed residential development without any supporting water infrastructure. Instead, they felt that growth should be concentrated in specific areas of the "El Centro" Growth Management Area in order to concentrate infrastructure needs and the environmental impacts of housing, and to limit future commuting miles (energy use), while keeping the Galisteo Growth Management Area largely available for the enjoyment and preservation of its ecological, hydrological, cultural, and scenic values.

The meetings revealed that stakeholders roughly recognize the same open space conservation hubs in the watershed as identified in the Green Infrastructure Plan. The public's identification of conservation areas (places of Querencia) were often overlapping. One should conclude that the overlap areas are relevant for different communities of place, and are therefore potentially of a high collective interest and/or of collective importance as transition zones (and in some cases also as links or corridors) between the cores of different places of Querencia.

Finally, the meetings confirmed that Santa Fe County and the State of New Mexico have few incentive programs in place to support conservation practices and conservation-oriented development schemes for individual landowners. However, the preliminary outcomes of the Green Infrastructure Plan and the GWP meetings have informed County

planners about preferences and strategies for the development of the County's growth management plan. Santa Fe County's Sustainable Growth Management Plan has developed new zoning restrictions regarding residential development and mineral and oil and gas production in and adjacent to flood zones, near cultural and historic sites, in wildlife habitat areas, and on specific soil complexes. These new growth management regulations will enable Santa Fe County to direct development to areas that are more suitable for such land uses, while preserving areas that are more suitable for significant conservation values.

Santa Fe County ultimately changed its planning strategy and is no longer looking at the county by districts. In 2010 Santa Fe County adopted a Sustainable Land Development Plan (in lieu of the Growth Management Plan as was previously contemplated) which designates portions of the County as "Priority Management Areas." The County will draft the code for the Sustainable Land Development Plan in 2011, and it is this code that will help to define how the Priority areas will be managed.

2. Review of the Plan by the County Open Lands, Trails and Parks Advisory Committee (COLTPAC).

In mid 2007, Earth Works Institute (EWI) and SFCT staff presented to COLTPAC its Green Infrastructure Plan and a preliminary extrapolation of the plan for the entire county. The County Open Space and Trails Program identified a large number of parcels in the Galisteo Basin with high conservation values and therefore worth conserving. Going forward, ongoing coordination of conservation and restoration initiatives in the Galisteo Basin between the County Open Space and Trails Division, COLTPAC, SFCT, and EWI will be useful for the implementation of the Green Infrastructure Plan for the Santa Fe County Sustainable Growth management Plan, as adopted in December 2010.

3. Review of the Plan by County officials.

In view of the ongoing County strategic planning process and an anticipated regional plan for parts of the Galisteo Watershed, the Plan was reviewed by County officials involved with growth management planning. In 2007, EWI and SFCT staff presented a draft of the Green Infrastructure Plan to County planning staff. In the fall of 2007, Santa Fe County combined the County Land Use Department, Water Resources Department, and Public Works Department into one Growth Management Department. Additionally, most of the Galisteo Basin was identified as one growth-management zone: the Galisteo Growth Management Area. This designation will allow the implementation of conservation measures and Green Infrastructure Plan elements as specific features of this growth management area.

4. Review of the Plan as part of a Management Plan development process for BLM units in the watershed.

EWI and SFCT staff should continue to reach out to BLM to seek coordination between the Green Infrastructure Plan and the new management plan for BLM parcels in the region.

5. Review of the Plan in the planning process of State Land Office holdings in the watershed.

EWI and SFCT staff should reach out to the State Land Office to inquire to what extent the Green Infrastructure Plan can be adopted and implemented in the management plans for State Land Office parcels.

6. Development of a tourism plan (ecotourism and cultural heritage tourism) for the watershed.

EWI and SFCT staff should reach out to County Growth Management staff to inquire to what extent the Green Infrastructure Plan can inform and catalyze an ecotourism and heritage tourism plan and/or the planning of a cultural heritage designation for the Galisteo Basin.

7. Review of the Plan by Santa Fe Conservation Trust and other conservation organizations to establish conservation easements (CEs) with landowners.

The Green Infrastructure Plan should be reviewed by Santa Fe Conservation Trust and other conservation organizations for the prioritization of their efforts of establishing CEs with landowners. SFCT and other conservation organizations should continue to reach out to landowners in priority areas to inform them about conservation easement opportunities. Such opportunities should, for example, be offered and pursued with landowners of significantly large ranches and, where possible, with landowners of newly acquired and developed ranchettes.

8. Review of the Plan by ranch owners and conservation developers to fine-tune ranch management and conservation development plans.

The Green Infrastructure Plan should be reviewed by ranch owners and conservation developers in dialogue with the GWP to fine-tune ranch management and conservation development portions of the open space plan. EWI and SFCT staff should approach ranch owners to ask them to consider the Green Infrastructure Plan and identify those pieces of the plan that they might want to pursue and refine for conservation-oriented ranch development, resource commercialization, and/or land stewardship. EWI and SFCT are available to assist ranches with referrals and technical assistance to seek solutions for land development schemes that meet both income and conservation/protection objectives.

9. Review of the Plan by traditional and contemporary communities in dialogue with the GWP to seek fine-tuning of community plans and their open space components.

During the formation of community stewardship teams (as part of EWI projects for stream and wetland restoration) and in the County process of creating and guiding community planning, Santa Fe County, EWI, and SFCT should invite communities to consider adopting the relevant Green Infrastructure Plan recommendations into community plans and stewardship actions.

10. Refine the Plan’s implementation section to make the Green Infrastructure network design a reality.

Follow-up studies by EWI, SFCT, Santa Fe County, and others should refine the Green Infrastructure Plan and use its components to formulate specific funding proposals for Plan implementation.

11. Developing a management and stewardship plan and organizational mechanisms (e.g., one or more Community Stewardship Organizations) that address the restoration and maintenance needs of the Green Infrastructure network components.

In conjunction with issue 10 above, Santa Fe County, community planning teams and conservation groups such as EWI and SFCT should pursue the development of community-based stewardship teams to direct the implementation and maintenance of site-specific projects for the implementation of the Plan. It would be desirable if ranch owners could join the team of a nearby community.

12. Educating the public (specifically open space users, landowners, and youth) and elected officials about the Plan.

The public and elected officials should be educated about the Plan, and should be included in Green Infrastructure management and stewardship. Santa Fe County and conservation organizations could, for example, through the GWP, establish a long-term public education campaign to promote the Green Infrastructure Plan. This would be important to obtain people’s “buy-in” and ongoing support for the GWCI and the Green Infrastructure network over time. Additionally, signage of landscape features, interpretive trails and signs, booklets, a website, and educational outreach activities and events could be developed to support this effort.

3.2 RESULTS: CONSERVATION AND RESTORATION PILOT PROJECT

Pilot Project Site Description

The selected conservation pilot site is located in the “Central Bowl,” the primary green infrastructure hub in the Galisteo Basin. The Central Bowl is of primary importance due to its central location, its diversity in conservation values and sites, and a high concentration of priority areas of significant conservation value (SCV). The pilot site is located in the 12,800-acre open space portion of a planned conservation development community: the Galisteo Basin Preserve.

The Galisteo Basin Preserve is being managed and developed by Commonweal Conservancy of Santa Fe. The open space designation of the area will, once established, guarantee indefinite open space conservation status to the pilot site and its surrounding landscape. The conservation status will be enforced through conservation easements, which will most likely be held by the Santa Fe Conservation Trust. The selected conservation pilot site is located in an unnamed tributary to the

Arroyo de Los Angeles. For our purposes, we have called the tributary the Southwest Arroyo. The pilot site has significant geologic and scenic values, potential wetland habitat values, hydrological values, and wildlife habitat (corridor) values. The GWCI team anticipates also that the site and/or its immediate surroundings may include certain features of archaeological importance. The GWCI team contracted with Stephen Townsend, a consultant who conducted a concise archaeological survey in order to ensure the protection of any potential archaeological sites or findings.

In 2005, Earth Works Institute surveyed the Galisteo Basin Preserve for wetland areas and wetland potential as part of the initiative “Planning for Wetlands in the Galisteo Watershed.” Several wetland areas were located and mapped with GIS. The Southwest Arroyo, just south of the Galisteo Basin Preserve’s prospective Trenza village site, was found to have intermittent wet areas and wetland vegetation. The arroyo is narrow and steep, with sandstone walls and a scenic, meandering channel. The potential exists in this arroyo to increase the wetland vegetation and to establish a small riparian forest with cottonwoods and willows.

During a walk-through of the Southwest Arroyo, Earth Works Institute staff found a stable reach upstream of the restoration site. Earth Works used this reach as a reference reach (section of the arroyo) to serve as a model for the restoration work downstream (see Figure 3.1). This portion of the arroyo channel has a broad, well vegetated floodplain and two medium-sized cottonwood trees. The area was surveyed for the physical and vegetative parameters that contribute to the health of the channel. The parameters were used to design the restoration project downstream.



Figure 3.1 Reference reach in Southwest Arroyo, in 2005 and in early 2008. (Photos: Steve Vrooman (left) and Jan-Willem Jansens (right).)

The pilot project reach is about 1,000 feet of channel near the confluence of the Southwest Arroyo and the Arroyo de los Angeles. The channel has lost access to its floodplain and has cut down to the sandstone bedrock in several places (see Figure 3.2). However, there is wet sand throughout most of the channel and several areas with *Juncus balticus*, a wetland obligate rush species. Since the initial investigation in 2005, the removal of cattle from the Preserve has allowed vegetation to spread across the channel, which will help store sediment and raise the channel back to its former level. For example, coyote willows, which were not visible during the initial investigation in 2005, are now growing in the channel.

Description of the Conservation and Restoration Pilot Project Implementation

The site restoration design by Earth Works Institute included the installation of a series of restoration structures in the arroyo, such as rock cross-vanes, weirs, and vanes, to lengthen the channel and capture sediment (see Figure 3.3). The additional sediment would hold groundwater and provide a substrate for the growth of wetland vegetation. In addition, raising the grade was to increase the flow of water across the floodplain during flood events and increase the area of water storage, as water that accesses the floodplain would be stored in the floodplain sediment.

Earth Works Institute expected that it would take 3-5 years after the installation of structures for the channel to gain its new elevation and for sediment to accumulate behind the structures. In reality, a few large storms in the summer of 2008 assisted in achieving these desired conditions within one year. Several of the structures were entirely buried in sediment or breached. The channel accumulated large amounts of sediment and soil moisture, which allowed the riparian and wetland vegetation to expand and flourish.



Figure 3.2 Pilot project reach, August 2005; the floodplain is inaccessible to flooding. (Photo: Steve Vrooman)

Pilot Project Implementation

The Earth Works team implemented the pilot project in December 2007 and January-February 2008 (see figure 3.4). Design and implementation costs were limited to about \$15,000.

Pilot Project Monitoring

The project team anticipated that monitoring would be performed by Charter School 37, UNM students, and Earth Works Institute staff. Monitoring would take place in the spring and fall of each year, and be part of additional wetland monitoring activities throughout the Galisteo Basin. The Earth Works Institute team, assisted by students from Charter School 37, collected quantitative baseline data on stream dimensions and the size of the wetland patch in the arroyo. Additionally several photo points (permanent points for photo monitoring) were established. Earth Works Institute staff conducted occasional follow-up monitoring, consisting of stream measurements and photo points.

The anticipated social and cultural monitoring was not taken up in a systematic way. However, ongoing research at the Galisteo Basin Preserve did address some of these aspects. A survey by Gretel Follingstad in 2008 generated feedback on people's interest in the place, public learning opportunities, and public recreation needs. No information was collected about people's investments in the land's health and ecological productivity. Due to a slowdown in the development of the community at the Galisteo Basin Preserve, to date, a conservation easement for the area around Southwest Arroyo has not been put in place.



Figure 3.3 Small cross-vane just downstream from the existing wetlands. February 2008. (Photo: Jan-Willem Jansens)



Figure 3.4 Looking upstream across a rock sill. February 2008. (Photo: Jan-Willem Jansens)



Photo: Mark L. Watson

4

RECOMMENDATIONS

4.1 RECOMMENDATIONS: GREEN INFRASTRUCTURE PLAN FOR THE GALISTEO WATERSHED

Conservation Criteria Recommendations

Implementation of the Green Infrastructure Plan should consider the following general criteria when targeting potential conservation sites:

- The degree to which a site/area protects or adds to the contiguous nature of a hub or corridor (degree of reduction of fragmentation)
- The degree of threat of losing the significant conservation value of an area or the degree to which fragmentation may occur if the area were not protected
- The level of priority (significant conservation value) given in the GIS analysis process
- Feasibility and opportunity (local interest, affordability, large acreages)
- Areas that best represent the character of the watershed and protect or enhance the integrity of the landscape

Conservation Area Priorities Recommendations

See Appendix J for a table providing a comprehensive overview of areas recommended as priorities for future land and resource conservation and restoration initiatives.

Conservation Tools Recommendations

Residents, communities, conservation organizations, local government, and public land management agencies can choose from a diverse set of planning mechanisms to implement a green infrastructure plan. A combination of mechanisms — or tools — and a collaborative partnership of stakeholders and service providers will be most effective for implementing a site-specific project or component of a green infrastructure plan. Green infrastructure conservation tools that are appropriate for the Galisteo Basin include:

1. **Land acquisition:** Santa Fe County's Open Space and Trails Division has acquired land for open space conservation. A few areas are still under consideration for acquisition by the Board of County Commissioners.

2. **Private Conservation Easements (CEs):** The Santa Fe Conservation Trust has secured approximately 2,856 acres of conservation easements in the Galisteo Basin. The Nature Conservancy, Commonweal Conservancy, the Archaeological Conservancy, Taos Land Trust, and Forest Trust also hold conservation easements in the Galisteo Basin. Conservation easements will be the most important tool in securing open space, as about 69% of the land is privately owned. Under certain conditions, state and federal tax benefits can accrue to conservation easement donors. As of 2008, state tax credits for conservation easement donations are transferable to other New Mexico taxpayers, making it easier for “land-rich/cash poor” landowners to become conservation easement donors.
3. **Floodplain management:** Santa Fe County applies FEMA map documentation and the County Land Use Code to prevent development of the floodplain in the watershed. This ensures that the floodplain and most of the alluvial banks of the Galisteo Creek remain de facto open space.
4. **Smart growth management tools:** Santa Fe County’s Sustainable Growth Management Plan includes a variety of growth management tools. A tiered growth management approach will lead to postponement of urban development in the Galisteo Basin for many decades and prescribes development to be concentrated in specific areas.
5. **Conservation land development:** Commonweal Conservancy is pioneering a conservation development project on the former Thornton Ranch. This development, Trenza, will concentrate 965 dwellings within a development envelope of approximately 300 acres, while placing more than 12,800 acres in permanent open space. The open space landscape is ensured through the concentration of development rights via transfers, the placement of conservation easements, and the establishment of tracts that serve as memorial landscapes (natural burial environments). The open space area will probably be managed through a Community Stewardship Organization. If successful, Commonweal’s pioneering activities in this field may be followed by other landowners in the watershed. Currently several other development projects include attempts to cluster home sites, reduce construction footprints, and place restrictive covenants on home lots to ensure contiguity of open alluvial grasslands and undisturbed woodland clusters.
6. **Community planning:** Santa Fe County has engaged in collaborative planning processes with communities in the Galisteo Basin. Community plans for Cerrillos, the San Marcos District, Eldorado, and the Highway 285 corridor are complete, and a community plan for the Village of Galisteo is underway. In these community planning processes, residents have indicated a strong preference for keeping a “rural character,” limiting residential growth, and maintaining open lands along highways.

- 7. Educating landowners and establishing collaborative partnerships with or among landowners:** Santa Fe Conservation Trust and Earth Works Institute have begun initiatives to educate landowners about the possibilities of land conservation and open space preservation. Landowners in the watershed also collaborate to some extent to keep dirt roads unpaved and minimize the use of groundwater sources in order to minimize outside interest in purchasing property in their neighborhoods.
- 8. Planning mechanisms:** A working group of the Galisteo Watershed Partnership met in 2007 to review the Santa Fe County Development Review process and suggest mechanisms for the conservation of open space in the northern part of the watershed (the Rancho Viejo grasslands hub and the northern part of the central hub, particularly on the Galisteo Basin Preserve). The group identified that the Transfer of Development Rights (TDR) mechanism has not worked in the Santa Fe area because there was no ready market and no marketing program for TDRs. The group suggested that it might be worthwhile to work with Santa Fe County to study the possibilities of establishing a Public Improvement District (PID) or Special Assessment District (SAD) for this area. PIDs are typically used in areas that are not yet developed, while SADs are applied in areas that are developed. The PID and SAD processes will require developers and/or residents to contribute financially to publicly managed projects for land improvement and management. This could include land acquisitions for open space, trail development, erosion control, etc. In 2009 and 2010, various parties and County staff also considered developing a special rural overlay district for the Galisteo Basin. By late 2010, various options and variations were still being investigated.
- 9. Land swaps:** Strategic exchanges of public and private land parcels, managed by the State Land Office and the BLM, may help in creating de facto open space in areas where public lands are created, finance development opportunities on the retired public lands, and create additional open space conservation projects in association with the development project. For example, Rancho Viejo Partners has recently been negotiating a land swap with the State Land Office and the Santa Fe County Open Space Division.
- 10. Lands designated as parks, open space, or monuments:** Public land management agencies and Congress can designate areas to become protected as state or national parks, monuments, recreation areas, heritage areas, and/or open space areas. Such designations are typically accompanied by land purchases and/or a management strategy. For example, in 2005, the National Park Service purchased about 50 acres of land in Cañoncito for the Glorieta Battlefield site as part of the Pecos National Monument. In 2008, Santa Fe County and the Galisteo Basin were included in the Northern Rio Grande National Heritage Area. When funded, this designation may bring land protection and economic development

projects to the Basin. In 2009, the State Parks Division was appointed as the managing agency of the Cerrillos Hills state park. Other options for state park development in the Galisteo Basin continue to be pursued. These designated areas add considerably to the green infrastructure for historical and recreational purposes as well as for open space qualities.

Land Health Restoration and Land Stewardship

Land health restoration should focus on the recommendations of the Galisteo Watershed Restoration Action Strategy (WRAS) of July 2005. In the context of the priorities identified in the Green Infrastructure Plan, restoration activities should emphasize:

- Rehabilitation of stream geomorphology, riparian habitat, and wetland conditions in Galisteo Creek, along its 40-mile run from Apache Canyon to the Rio Grande
- Runoff management, water harvesting, and erosion control (i.e., gully and headcut stabilization) in the buffer zones between existing and planned development areas and drainages and in buffer zones around wetlands and other ecological areas of high conservation value
- Improving contiguity in wildlife linkage areas (fence adjustments, grassland production improvement, water source improvements, and safe highway passage solutions)
- Managed grazing of grasslands and woodlands
- Thinning of dense juniper stands, introduction of controlled burns (where possible), and selective thinning and harvesting of invasive tree species in riparian habitat

Land Health Assessments, Land Evaluation and Site Assessments (LESA), and Riparian Evaluation and Site Assessments (RESA) may help determine local land health problems and the need for and nature of specific land restoration activities. Activities could possibly be structured most advantageously when stewardship work is conducted with specific neighborhoods or small communities that are willing to and capable of taking an active stewardship role.

Strategies for Ongoing Land Stewardship in the Watershed

The development of ongoing land stewardship mechanisms will be essential for maintaining and enhancing the green infrastructure network, and for maintaining the vitality and productivity of the open space landscape. Several strategies may be considered to help achieve ongoing land stewardship goals:

- Creation of “EcoWise Communities” and/or groups that “adopt” an area, a stream section, or a site. Stewardship actors could include residents, conservation groups, public agencies, schools, and youth corps teams with sponsorship from local businesses, government agencies, or private donations.
- Creation of Community Stewardship Organizations for open space associated with a development project
- Creation of an integrated bosque/wetlands/stream corridor project, with support from Project BEMP (Bosque Ecological Monitoring Project) and other programs, to protect and restore the Galisteo Creek and associated wetlands and habitat
- Development of an ecotourism action plan that incorporates interpretive communications planning and associated stewardship and docent teams
- Collaboration between archaeological conservation groups and soil and water conservation groups for joint erosion control and drainage management actions
- Watershed-wide monitoring systems, along with agreements and policies on pronghorn movement and migration management (fence management, outreach and education, view spots, grassland improvement, watering holes, etc.)
- Watershed-wide monitoring systems, along with agreements and policies on cougar, bear, and deer movement and migration management
- Watershed-wide monitoring systems, along with agreements and policies on surface and groundwater flow management to ensure sustainable water availability for wetlands, streams, and springs
- Development of managed, restorative grazing schemes, preferably in collaboration with local livestock (goat or cattle) operators, and associated monitoring protocols in order to improve grassland and woodland health while stimulating local land-based businesses.
- Periodic selective harvesting of saltcedar (tamarisk) and Russian olive and pruning of native trees to invigorate riparian areas, and putting the wood products and byproducts to economic use

- Development of a composting business for land restoration purposes with the use of local horse manure, vegetation waste, and wood chips (e.g., from harvested wood material)

These suggested land stewardship projects would focus on creating local jobs and other economic incentives, while providing an educational modeling function (for youth corps, landowners, and local school and college programs) and gradually restoring land health in the open space areas.

Anticipated Benefits and Costs

Governments, communities, planners, and individuals around the world are discovering the benefits of green infrastructure. The Conservation Fund's Green Infrastructure Program (Conservation Fund, 2007) is one of many nationwide efforts to help communities integrate conservation into development planning. Addressing both natural and human needs, green infrastructure provides public and private values and functions, creating a framework for future development while it protects and restores the functions of natural ecosystems, providing a range of social, ecological, and economic benefits in the process:

- Cleaner air and water
- Increased property values
- Decreased costs of public infrastructure and services, including erosion control, stormwater management, and water treatment.
- Enriched habitat and biodiversity
- Maintenance of natural landscape processes
- Increased recreational and transportation opportunities
- Business, job, and revenue opportunities from local tourism, recreation, ranching and agriculture, land stewardship, restoration, and terrain management activities
- Improved human health conditions
- Better connection to nature and sense of place
- Partnerships and coordination between communities

As stated on The Conservation Fund's Green Infrastructure Program's website,

Investing in green infrastructure can often be more cost effective than conventional public works projects. For example, in the 1990s New York City avoided the need to spend \$6–\$8 billion on new water filtration and treatment plants by instead purchasing and protecting watershed land in the Catskill Mountains for about \$1.5 billion. Likewise Arnold, Missouri, has dramatically reduced the cost to taxpayers of disaster relief and flood damage repair by purchasing threatened properties and creating a greenway in the flood plain.

Recognizing the value of natural infrastructure, other organizations, including Urban Logic and the Center for Neighborhood Technology, are working with economists and accountants to help governmental accounting standards capture the natural environment's inherent capital as part of balance sheet reporting.

Since about 2005, private sector initiatives and public-private partnerships have increasingly developed financing schemes that seek to monetize nature's benefits to pay for long-term, landscape-wide ecosystem conservation and restoration initiatives. To date several hundred so-called Payment for Ecosystem Services programs have been established in states such as California, North Carolina, and Maryland. Regulatory enforcement of clean water standards, wetland standards, or biodiversity (i.e., listed species) protection targets and/or a system of voluntary credits to achieve such standards and targets drive these projects. Ecosystem health improvements are monitored by accredited institutions, which secures a permanent value of regulatory offsets and voluntary credit payments toward tangible improvements (and associated monetary gain) in the marketplace over time.

For example, the Chesapeake Bay Ecofinance Corporation has purchased several farms on the eastern shores of the Chesapeake Bay to convert the properties to forms of production that meet EPA regulatory emissions standards, while increasing the value-added output of the farms. A combination of higher returns for farm products, elimination of emission fees, increased real estate value of the farms, consulting revenues from Best Management Practices, and voluntary nutrient (emissions) credits, must pay over time for the costs of conservation easements and farm acquisition, conversion, and resale costs.

In another example, close to home, the City of Santa Fe has entered into an agreement with the U.S. Forest Service for the management of the Upper Santa Fe Watershed. Forest management practices over the last ten years included the large-scale thinning of the watershed with the ecological benefits of a strongly reduced risk of catastrophic wildfire and increased water quality in the drinking water reservoirs on which the City relies for about 40% of its supply. Through a surcharge on drinking water fees the City pays the Forest Service (and associated non-governmental watchdog and research partners) for ongoing monitoring and forest management practices, while the City is able to save on investments for water purification and backup facilities. Ongoing research of the ecosystem functions of, for example, wetlands and

wildlife habitat in the Galisteo Basin may generate similar Payment for Ecosystem Services programs that help finance the conservation and restoration of the fragile landscapes of the Galisteo Watershed Green Infrastructure.

Costs of Green Infrastructure

Green infrastructure functions may have been provided free of charge by nature, but maintaining them is not without costs. Protection of green infrastructure—whether through the efforts of individual landowners, communities, public agencies, or non-profit organizations—requires investment, including the costs of:

- Land acquisition
- Conservation easement creation
- Restoration and mitigation activities
- Ongoing stewardship activities
- Coordination, education, etc.
- Monitoring

It is beyond the scope of the Galisteo Watershed Conservation Initiative to identify cost estimates for the various components of the plan presented in this document, even if we concentrate on the areas of the highest conservation value—many of which should ideally be addressed with public funding support. Costs may also vary based on financing structures, partnership financing options (cost sharing and collaboration), and implementation timeframes.

4.2 Recommendations: Conservation and Restoration Pilot Project

The implementation of the conservation pilot project revealed several important lessons for the future implementation of the Green Infrastructure Plan.

Landowner interest and cooperation is essential and determines the practical feasibility of conservation projects and, hence, what areas are immediately available for conservation projects. Ongoing communication between conservation organizations and landowners about their goals for land use, land management, conservation and their financing options for land management strategies is critical in achieving conservation goals on private lands.



The Conservation and Restoration Pilot Project provided lessons that will prove valuable for future conservation efforts.

1. The prioritization of the on-the-ground allocation of means for conservation projects is often driven by feasibility regarding landowner cooperation and funding availability and funding conditions. These conditions readily supersede the urgency of conservation in certain key areas. Therefore, long-term strategic planning is necessary to ensure that key conservation areas are being protected when they become available for protection (and that funding and personnel resources are reserved to materialize their protection at the opportune time). Ironically, conservation and restoration projects may become as easily fragmented as the landscape that we want to protect from fragmentation by applying conservation measures. In the worst case, this will generate a certain number of isolated open space areas, but not the needed contiguity (for ecological integrity), connectivity (e.g., for wildlife movement and recreational trails), and landscape-wide ecological processes that are binding open space areas together in a green infrastructure network.
2. The preparations for a land rehabilitation or conservation project are time consuming and complicated. Issues of ownership title, county zoning, and master plan approval for land use changes, ecological surveys, archaeological surveys, and community education need to be taken into consideration and be coordinated between different parties before specific rehabilitation and/or conservation actions may be feasible or relevant. In some cases, it may be impossible to synchronize site rehabilitation and land conservation (legal protection), which may jeopardize the impact and success of the rehabilitation efforts and/or the purposes of land conservation.

4.3 Final Conclusions and Recommendations

The following conclusions and recommendations are intended to support the implementation of the Green Infrastructure Plan for the Galisteo Watershed and the dissemination of the GWCI Green Infrastructure planning concept in other areas.

Implementation of the Green Infrastructure Plan in the Galisteo Basin

The Galisteo Watershed GIS database is intended to be a dynamic and evolving resource. As new data are gathered, they can be added to the growing body of knowledge about the watershed and its resources.

The project team proposes a few modifications that will help refine the GIS model:

1. The project team considered that land fragmented by paved roads and highways constitutes a reduced conservation value due to ecological fragmentation, noise, and visual quality disturbance in viewlines toward the roads and highways. Land (i.e., habitat) fragmentation and noise reduce the value of the land for wildlife habitat functions, and road runoff and stream modification near bridges typically affect the value of water bodies and riparian areas. As a result, grasslands, woodlands, and forests with a paved road density of more than one mile per square mile were not classified as having significant conservation value in this initial model.

In hindsight, the project team realizes that the paved road density level of one mile per square mile raster block eliminates significant portions of grasslands, woodlands, and forests from the prioritization of open space areas and does not accurately indicate the potential open space value of the landscape. Impacts from roads and highways are very location-specific. Additionally, experiences of open spaces' scenic and recreation values often originate on roads and highways. The raster model output has led to a removal of blocks of one square mile in areas with road densities of more than one mile per square mile, particularly visible in the composite output maps where values along highways have been reduced to an unnatural block pattern. As a result, the maps do not accurately represent the more gradual and site-specific reduction (or appreciation) of conservation values along highways. Future models and an updated version of the Green Infrastructure Plan for the watershed will need to be corrected for these factors.

2. The project team believes that lack of data for this project has probably generated a bias of composite values to the detriment of National Forest lands and mountain areas. Because most National Forest lands are located in mountainous terrain, the conservation values attributed to the National Forest lands may in some places have resulted in cumulative underestimations (for both National Forest lands and mountainous terrain). The underestimated potential open space value of National Forest lands may be of little consequence to the primary users of the Green Infrastructure Plan (local conservation groups and local government) due to their limited control over these federal lands. However, at a larger scale, the National Forests are an important open space hub, which determines the context of other open space areas of significant conservation value in the watershed. Future models and an updated version of the Green Infrastructure Plan for the watershed will need to be corrected to better reflect the conservation values of forest lands and mountain areas.

Recommendations for Future Use, Public Outreach, and Plan Implementation

The GWCI team envisions several ways to ensure that the Green Infrastructure Plan will succeed well into the future:

1. Project implementation should be initiated by any agency or institution that feels compelled to take action. When implementing portions of the plan, these entities should consider establishing stewardship teams for each implementation task and/or area. Teams or coalitions should ideally include residents, conservation groups, businesses, county departments, schools, and relevant state and/or federal agencies.
2. Santa Fe County should consider establishing a working group or task force under the County Development Review Committee (or Planning Committee) for each of the four County Growth Management Areas. The Galisteo Watershed Partnership (GWP) could serve as a recognized Community Organization that acts as one of the constituency groups for this committee. Financing for the Green Infrastructure Plan implementation should be further explored and should ideally be part of County projects in the Galisteo Growth Management Planning Area. One possible mechanism is a Rural Overlay District that is financed with bond funds to support specific “grey” and “green” infrastructure improvements in the Growth Management Department. Perhaps property tax breaks could be issued in the future to landowners who have a land or resource management plan in place and/or implement certain conservation and restoration practices (e.g., having a CE, having a planned grazing scheme, conducting stream and wetland restoration work, conserving water resources, etc.), in accordance with a terrain management handbook and/or land management practices “code.” The burden should be on the landowner to prove the applicable practices.
3. Monitoring of terrain management and land management practices should be delegated to conservation organizations (similar to the monitoring of CEs) and regulated through conservation and stewardship contracts. Conservation and stewardship contracts should be accompanied with an endowment that finances the work of the conservation organization in monitoring, repair, and public education.
4. More dialogue and mutual learning is needed to reconcile archaeological and ecological conservation and rehabilitation objectives and specific techniques. It appears that too often the strategies and objectives of these two disciplines are diverging, while they could potentially be mutually supportive of each other and strengthen their respective landscape values in the integrated context of a green infrastructure plan.

Recommendations for Further Study

Plan implementation should be accompanied with adequate public feedback. A series of meetings of the GWP in 2007 and 2008 generated significant insights into local stakeholder preferences and largely confirmed and detailed the proposed green infrastructure recommendations in this plan. However, several topics should be further investigated with local stakeholders, such as:

- Scenic preservation strategies and interpretive planning and site and trail development
- Ecotourism and heritage tourism development strategies
- Identification of pilot projects with ranch owners
- Comprehensive stream and arroyo management planning (buffer zones, governance and stewardship responsibilities and guidelines, terrain management handbook development, and ideas for establishing long-term collaborative and educational stewardship and rehabilitation programs for priority areas)
- Creating a wider support mechanism for conservation of cultural and historical sites, including public education on this topic, and pursuing national and state designation status for long-term conservation and stewardship of certain conservation areas of significant value
- Educating residents and youth about conservation-oriented living, and developing and providing incentives for individual stewardship practices
- An analysis of the relationships between real estate prices and identified conservation values to help determine whether such values are positively related to price trends for properties in the watershed. Similarly, an analysis of lot splits and real estate turnover in certain areas in contrast with identified conservation values may reveal to what extent property fragmentation, rapid landowner turnover, and land use and urban development trends in certain areas threaten the conservation value of the land, and, hence, indicate a need to seek long-term land and natural resource conservation measures.

Further Application and Dissemination of the GWCI Concept

The GWCI team envisions several ways of making the GIS tool and the output more user-friendly and replicable for use in other areas. The GWCI team incorporated several suggestions for additional analysis steps to identify open space conservation priorities. The current product enables users to conduct additional analyses with the existing models and enrich or modify the outcomes to satisfy their specific objectives.

Additional GWCI product improvement and development could include:

1. GIS tool and output improvement, refinement, and enhancement:

- The gathering, analysis, and inclusion of additional GIS data layers in the SCV modeling process (such as Threatened and Endangered Species data, Terrestrial Ecosystem data, BLM and Forest Service watershed analysis data, wildlife habitat data, and updated soil data to analyze buffer zones and eroded lands)
- The adjustment of the road density parameters regarding highways and single roads crossing grasslands and forests
- The inclusion of the spatial framework of the landscape to identify existing open space hubs and corridors that should form the core of the Green Infrastructure Plan
- Gathering and inclusion of public feedback (from neighborhoods, layperson groups, and tribal communities interested in the watershed) to capture the “storied” landscape and its popular values
- The analysis and evaluation of detailed areas in the watershed regarding land health (for example, through land health mapping in certain parts of the watershed) and land use suitability (for example, through Land Evaluation and Site Assessment—LESA—and Riparian Evaluation and Site Assessment—RESA—processes) to generate additional indicators for conservation priorities and restoration priorities
- The modeling of soil data in the SCVM to analyze and prioritize areas that need to be protected and restored due to current and expected soil and ecosystem degradation

2. GIS tool storage, management, and public access (through a website, Santa Fe County and/or the State of New Mexico)

3. Strategic replication and packaging for application in other watersheds.

The GWCI project team cautions users that the GIS tool and output is limited by the data sets that were available to the project and to the analysis steps chosen in the methodology.



APPENDICES

APPENDIX A: TERMS AND ACRONYMS

ACE: (United States) Army Corps of Engineers

BEMP: Bosque Ecosystem Monitoring Project, a long-term ecological research project using student volunteers to monitor key indicators of structural and functional change in the Middle Rio Grande riparian forest, or “bosque.”

BLM: Bureau of Land Management

CORRIDOR: See Hub and Link.

CE (CONSERVATION EASEMENT): A legal agreement that permanently retires the development rights on all or part of a property. Conservation easements are donated (or sometimes sold) to a qualifying non-profit organization, usually a land trust, by the landowner. Once put in place, the conservation easement rides with the property in perpetuity (i.e., all subsequent owners of the property are bound by the restrictions of the easement). Donated conservation easements are considered charitable gifts, and as such tax benefits may accrue to the original donor.

COLTPAC: County Open Lands and Trails Planning and Advisory Committee

CSA (COMMUNITY-SUPPORTED AGRICULTURE) FARM: A farm operation supported by a community of individuals, whereby growers and consumers provide mutual support and share in the risks and benefits of food production. CSAs rely on area residents to purchase “subscriptions” for weekly supplies of fresh produce. Typically, members or “shareholders” of the farm or garden pledge in advance to cover the anticipated costs of the farm operation and farmer’s salary. In return, they receive shares in the farm’s bounty throughout the growing season, as well as satisfaction gained from reconnecting to the land and participating directly in food production.

CWCS: Comprehensive Wildlife Conservation Strategy

DELPHI METHOD: A structured process for creating consensus by collecting and distilling knowledge from subject experts using carefully created questions, independent and collective response formats, and multiple rounds of input.

ECOREGION: A relatively large unit of land or water that is characterized by distinctive climate, ecological features, and plant and animal communities (e.g., Everglades Flooded Grasslands, Great Basin Lakes and Streams, and Chihuahuan Desert.)

ECOSYSTEM: A localized group of interdependent organisms, together with the environment that they inhabit and on which they depend.

ECOTONE: A zone of transition between two different ecological communities, e.g., where piñon/juniper woodland meets grassland.

ECOWISE COMMUNITIES: Communities that actively address the causes and impacts of climate change and natural resource degradation to promote healthy ecosystems and healthy interaction between human and natural communities.

ESRI: The leading developer of Geographic Information System (GIS) software.

EWI: Earth Works Institute, a Santa Fe non-profit organization.

FEMA: Federal Emergency Management Agency, the agency of the U.S. government that deals with disaster mitigation, preparedness, response, and recovery planning.

GALISTEO BASIN: For the purposes of this report, used interchangeably with Galisteo watershed. “Galisteo Basin” is the more commonly used term in Santa Fe County.

GALISTEO WATERSHED: The 730 acres of land surface forming the surface water drainage area that contributes water to the Galisteo Creek. The Watershed’s topography and life zones are varied and include coniferous forested mountains, rolling hills, arroyos, small lakes, seeps and springs, and alluvial floodplains.

GALISTEO WATERSHED PARTNERSHIP (GWP): Formed in 2005, a group of organizations and individuals—including ranchers, developers, non-profit organizations, and local, county, state and federal government agencies—whose purpose is to share information, organize public education initiatives, and serve as a coordinating body for outreach regarding planning, development and conservation initiatives in the Galisteo Watershed.

GBASPA: Galisteo Basin Archaeological Sites Protection Act (PUBLIC LAW 108-208-MAR. 19, 2004). The purpose of this federal act is “to provide for the preservation, protection, and interpretation of the nationally significant archaeological resources in the Galisteo Basin in New Mexico.” The act identifies 24 sites over 4,500 acres and authorizes the establishment of cooperative agreements and acquisitions and the withdrawal of these sites from extractive land uses.

GIS: Geographic Information System(s): a digital data storage, analysis, and processing tool that allows for complex, algebraic data comparison and manipulation based on databases of geographic attribute data that are linked to a three-dimensional system of geographic coordinates, the output of which can be made visible in printed map material.

GREEN INFRASTRUCTURE: The interconnected network of “waterways, wetlands, woodlands, wildlife habitats, and other natural areas; greenways, parks, and other conservation lands; working farms, ranches and forests; and wilderness and other open spaces that support native species, maintain natural ecological processes, sustain air and water resources and contribute to the health and quality of life for America’s communities and people” (Conservation Fund, 2007).

GREEN INFRASTRUCTURE PLANNING: A process that identifies suitable lands for conservation in the context of current and future developed lands. The primary objectives of green infrastructure planning are the identification and/or creation of “hubs and links for active and passive recreation, scenic amenity, farmland protection, urban forestry, urban wildlife, regional and state ecological systems, and the integration of conservation and growth management” (Randolph, 2004). (*See also* Green infrastructure)

GWCI: Galisteo Watershed Conservation Initiative

GWP: Galisteo Watershed Partnership

HEADCUT: A sudden change in elevation at the leading edge of a stream or river channel.

HUB: Open space hubs are large contiguous areas of undeveloped lands with conservation value. *See also* Link.

ISC: Interstate Stream Commission

LINK: Links are corridors between hubs that facilitate wildlife movement, water flow, and/or scenic or recreational connections. *See also* Hubs.

METADATA: Information about the sources and conditions of applicability and reliability of (GIS) data and data sets (e.g., pertaining to the date/time, location, frequency, and method of data collection, the geographic scope of data, the resolution — or level of detail — of data, and certain data processing and analysis that has taken place).

OPEN SPACE: “Open space” is a term used in two ways in this report. In general discussion, “open space” is natural or undeveloped land—whether used for agricultural purposes or left relatively untouched. Alternatively, “open space” data in the GIS model refers to land—whether public or private—explicitly set aside and placed under conservation easement or other protective measures for conservation, outdoor recreation, nature experience and/or other non-commercial and non-residential use.

OSE: Office of the State Engineer

PERCHING MEADOW: A formerly healthy meadow that has been separated from its source of moisture. In many locations, meadows along the Galisteo Creek and its tributaries have gradually been disconnected from the water table in the floodplain due to degradation (incision) of stream channels. These meadows are now perched well above the floodplain level, often leading to serious gully erosion moving up over time from the arroyo edge into the meadows.

PID: Public Improvement District

RASTERS: For the purposes of this report, the digital data layers that represent component or composite data sets of geographic information. Rasters can be printed in the form of thematic maps—maps relating to a specific theme, such as surface water flows, wildlife diversity, geology, soil cover, etc.

SAD: Special Assessment District

SCV: Significant Conservation Value

SCVM: Significant Conservation Value Model

SFCT: Santa Fe Conservation Trust

SMART GROWTH: An urban planning and transportation theory that concentrates growth in compact, walkable urban centers to avoid sprawl and advocates compact, transit-oriented, walkable, bicycle-friendly land use, including neighborhood schools, complete streets (streets designed to safely accommodate both auto and bicycle traffic), and mixed-use development with a range of housing choices.

TDR: Transfer of Development Rights. An approach to protecting natural open space in development planning that removes development rights from certain areas and concentrates them, thereby increasing allowable building densities on lands that are more suitable for development nearby.

VIEWSHED: An area of land or water with a scenic view quality that is visible from a fixed vantage point.

WATERSHED: A surface water drainage basin, i.e., an area in which all precipitation gathers in a central water body (stream or lake), which, in turn, empties again into a larger-order water body (river, lake or ocean).

WRAS: Watershed Restoration Action Strategy. A planning document that summarizes surface water quality impairments and presents an action strategy of solutions—including specific management strategies and stakeholder roles for implementation—to address water quality issues within a watershed management area or portion thereof.

APPENDIX B: REFERENCES

- Balmford, A., Bruner, A., Cooper, P., Costanza, R., Farber, S., Green, R. E., Jenkins, M., Jefferiss, P., Jessamy, V., Madden, J., Munro, K., Myers, N., Naeem, S., Paavola, J., Rayment, M., Rosendo, S., Roughgarden, J., Trumper, K., Turner, R. K. (2002). Economic reasons for conserving wild nature. *Science*, 297, 950-953.
- Benedict, M. A. & Bjornlund, L. (2002). *Green Infrastructure: A Strategic Approach to Natural Resource Planning and Conservation*.
- Biota Information System of New Mexico (BISON-M) (2007). Retrieved March 5, 2007, from www.bison-m.org
- Conservation Fund, The (2007). The Conservation Fund Green Infrastructure website. Retrieved March 5, 2007, from <http://www.greeninfrastructure.net>
- Costanza, R. et al. (1997). The Value of the World's Ecosystem Services and Natural Capital. *Nature* 387, 254-260.
- Earth Works Institute (2005a). *Galisteo Watershed Restoration Project (GWRP) – Phase II, Final Report*. Submitted to the New Mexico Environment Department Surface Water Quality Bureau – Watershed Protection Section. June 30, 2005.
- Earth Works Institute (2005b). *Watershed Restoration Action Strategy for the Galisteo Creek Watershed. An Adaptive Management Plan for Ecological Health of the Galisteo Watershed*. Version July 1, 2005. Under a grant from the State of New Mexico Environment Department – Surface Water Quality Bureau.
- Foreman D., Daly, K., Noss, R., Clark, M., Menke, K., Parsons, D. R., & Howard, R. (2003). *New Mexico Highlands Wildlands Network Vision. Connecting the Sky Islands to the Southern Rockies. Wildlands Project*. New Mexico Wilderness Alliance.
- ForestERA Project (2007). The Forest Ecosystem Restoration Analysis (ForestERA) Project; Forest Guild; and Queensland Centre for Advanced Technologies. *Multi-jurisdictional Application of ForestERA Landscape Decision Support Tools in North-Central New Mexico*. Funded by the Joint Fire Science Program. Missoula, MT.
- Griffith, G. E., Omernik, J. M. McGraw, M. M., Jacobi, G. Z., Canavan, C. M., Schrader, T. S., Mercer, D., Hill, R., & Moran, B. C. (2006). *Ecoregions of New Mexico* (color poster with map, descriptive text, summary tables, and photographs): Reston, Virginia, U.S. Geological Survey (map scale 1:1,400,000).
- Johnson, K. & Smith, J. (2005). *Cerro Pelon Ranch: Evaluation of Large Mammal Habitat*. Natural Heritage New Mexico. Biology Department, University of New Mexico. 18 February, 2005.

- Julyan, R. (1996). *The Place Names of New Mexico*. University of New Mexico Press.
- Lippard, L. (2006). Calvin Horn Lecture UNM, April 6, 2006. *Five Acres: Disputed Land and Disappearing Landscapes in the Galisteo Basin*.
- Lippard, L. and E. Ranney (2010). *Down Country: The Tano of the Galisteo Basin, 1250-1782*. Museum of New Mexico Press.
- McDonald, L., Allen, W., Benedict, M., & O'Connor, K. (2005). Green Infrastructure Plan Evaluation Frameworks. *Journal of Conservation Planning*, Vol 1/issue 1.
- New Mexico Department of Game and Fish (2006). *Comprehensive Wildlife Conservation Strategy for New Mexico*. New Mexico Department of Game and Fish. Santa Fe, New Mexico.
- Postel, S. & Richter, B. (2003). *Rivers for Life: Managing Water for People and Nature*, Island Press.
- Public Law 108–208 108th Congress (2004). *Galisteo Basin Archaeological Sites Protection Act*.
- Randolph, J. (2004). *Environmental Land Use Planning and Management*. Island Press. Washington, DC.
- Santa Fe County (1999). *Santa Fe County Growth Management Plan – General Plan*. Adopted by The Santa Fe County Board of County Commissioners Resolution 1999-137, October 25, 1999.
- Santa Fe County (2000). *Santa Fe County Open Lands and Trails Plan – For the Wildlife, Mountains, Trails and Historic Places Program*. May 15, 2000.
- Snow, D. H. (1994). *Archaeological and Historical Investigations. Barclay Ranch – La Gotera Grant*. Santa Fe County, New Mexico. April-May 1993. Prepared for The Conservation Fund. May 3, 1994.
- U.S. Bureau of Land Management (2004). *Galisteo Basin Archaeological Sites Protection Act and Planning Effort*. Taos Field Office. (Document includes Summary of the Act, copy of the Act, area map, and list of sites with ownership listing.)
- Vrooman, S. S. (2006). Assessment and Plan for the Creation, Restoration and Protection of Wetlands in the Galisteo Watershed. Earth Works Institute. As part of U.S. Environmental Protection Agency Cooperative Agreement with the New Mexico Environment Department.

APPENDIX C: STEERING COMMITTEE MEMBERS, AFFILIATIONS, AND CONTACT INFORMATION

Wetherbee Dorshow, M.A.

President, Earth Analytic, Inc.

Office: 227 East Palace Ave, Suite E, Santa Fe, NM 87501

Mailing: 7 Avenida Vista Grande #123, Santa Fe, NM 87508

Main Phone: 505/349-0407

wdorshow@earthanalytic.com

David Henkel, PhD

Former Program Director, Community & Regional Planning

School of Architecture & Planning

UNM

2414 Central Ave., SE

Albuquerque, NM 87106

505/277-1276

cymro@unm.edu

Jan-Willem Jansens

Executive Director

Earth Works Institute

1413 Second Street, Suite 4

Santa Fe, NM 87505

505/982-9806

jwj@earthworksinstitute.org

Beth Mills, PhD

Open Space and Trails Division (formerly with Planning Division)

County of Santa Fe

949 W. Alameda St.

Santa Fe, NM 87501

505/992-9857

bmills@santafecounty.org

Tim Murrell

(former Water Planner, Interstate Stream Commission, Office of the NM State Engineer)

230 W. Manhattan

Santa Fe, NM 87501

505/827-4029

tim.murrell@state.nm.us

Paul Olafson

Director, Community Project Division

County of Santa Fe

PO Box 276

Santa Fe, NM 87504-0276

505/992-9866

polafson@co.santa-fe.nm.us

Rici Peterson

Executive Director (2006-2010), Santa Fe Conservation Trust

505/699-2949 mobile

ricipeterson@gmail.com

Alan Ragins

Program Leader: Rivers, Trails, and Conservation Assistance

National Park Service

PO Box 25287

Denver, CO 80225-0287

303/969-2855

alan_ragins@nps.gov

APPENDIX D: DETAILED METHODS

Task 1: Developing a Method and Steering Committee

The SFCT/EWI established a steering committee consisting of:

- Wetherbee Dorshow, Earth Analytic (GIS Consultant)
- Dr. David Henkel, UNM - Community & Regional Planning (Program Director)
- Jan-Willem Jansens, Earth Works Institute (Executive Director)
- Dr. Beth Mills, Santa Fe County Planning Division (Planner; now with SF County Open Space and Trails Program)
- Paul Olafson, Santa Fe County Open Space & Trails Division (Director)
- Alan Ragins, NPS Rivers, Trails, and Conservation Assistance (Program Leader)
- Cyrus Samii and later Rici Peterson, Santa Fe Conservation Trust (Executive Director)

The team contacted GIS expert staff at various local, state, and federal government agencies to inform them about the project. Beth Mills and Wetherbee Dorshow met with GIS specialists to establish data sharing protocols and discuss the development of a data dictionary.

Earth Works Institute formulated a general project methodology, outlined below. Earth Analytic, LLC, developed a GIS methodology as an integral part of the general project methodology. The GIS methodology is included in Appendix E.

The general project methodology includes:

Step 1: Existing Open Space Definition Model

DEFINITION: Open Space includes all lands that are in some manner protected by a legal designation, including federal, state and local government designations, as well as private wilderness or park designations and lands subject to private conservation easements.

OBJECTIVE: To identify and categorize existing “open space.”

ACTION: Identify and categorize all existing open space and trails (protected vs. unprotected and private vs. public). Develop separate data sets for different kinds of open space that can be combined in one map.

Step 2: Preliminary Open Space Suitability Assessment (Significant Conservation Value Model)

DEFINITION: SCV Areas include those that meet selection criteria for high values of aesthetics (visual and spiritual values, etc.), land health (ecological functionality), recreation, land use patterns, public uses, rural economic development opportunities (agriculture and other non-urban, non-industrial economic development), and cultural resources.

OBJECTIVE: To identify undeveloped lands — not including existing open space — having significant conservation value, and to rank these areas in terms of relative conservation value (or conservation priority).

ACTION: Compile and overlay thematic GIS data sets related to open space. These include:

- **Model SCV-1:** Recreational Opportunities
- **Model SCV-2:** Scenic Values
- **Model SCV-3:** Significant Archaeological, Historical, and Paleontological Resources
- **Model SCV-4:** Significant Habitats
- **Model SCV-5:** Water-holding, Absorption, and Conveyance Zones
- **Model SCV-6:** Working Lands

A combination of Models SCV-1 through SCV-6 will generate Model SCV-7: Combined Conservation Priority. Model SCV-7 consists of a weighted result of all six models. In this step, all six sub-models will have an equal weight.

NOTE: During the course of the project Model SCV-1 and Model SCV-6 were removed from the model compilation process that would generate SCV-7, because the project team became aware that these two models represented land use values that were in part based on the landscape resource models in SCV2-5. Including the land use models would potentially lead to an implicit double counting of certain landscape values. Models SCV-1 and SCV-6 were, therefore, only used as reference models and not as overlay models for a final composite of weighted results.

Step 3: Terrain Sensitivity and Open Space Prioritization (Restoration and SCV Buffer Model)

In this step, we will identify areas which may not have any SCV (based on step 2), but which:

- Are in need of protection and/or rehabilitation to protect SCV areas adjacent to them (analysis on a sub-watershed basis)

- Should not be built on (flood-prone areas, steep slopes, reservoirs, ridgelines, etc.) and for that reason can serve as open space
- Are treasured by the public for historical, cultural, aesthetic, spiritual, and other reasons
- Are needed otherwise to buffer, connect or support (enhance the value of) SCV areas

This step includes two components: a restoration and SCV buffer model, and a data refinement component (Delphi Method).

3a. Restoration and SCV Buffer Model

- **Objective:** To identify undeveloped “marginal lands” (unbuildable, disturbed, and/or eroded) adjacent to or near existing open space and high-priority conservation targets and to rank them in terms of their relative potential to influence (negatively or positively) the quality of existing open space or potential conservation targets. The focus here is on lands where environmental restoration or protection from future degradation or development will have the highest positive impacts on nearby open space and conservation value lands.
- **Action:** Collect data sets models for terrain sensitivity, such as steep eroded lands near zones of high conservation value; steep-slope runoff and erosion (high erosion rates as per RUSLE) areas (based on our best knowledge, perhaps USGS, FEMA, NRCS).

NOTE: This step has been only partially implemented due a lack of project resources and a lack of available and reliable soil data. The restoration analysis did not take place. The buffer zone analysis was deferred to expert input (see next item).

3b. Data Refinement component (“Delphi Method” for expert input)

- **Objective:** To refine the SCV-1 through SCV-7 data sets and the data sets developed in the previous buffer zone models. The refinement includes the addition of spatial information on conservation values in the watershed and the modification of weighting values to arrive at a representation of conservation priorities based on the best wisdom available in the region.
- **Action:** Develop a prioritization method (related to Project Task 3), with support from a “Delphi approach.” This is a qualitative analysis of the data sets.

Results from this step are included in Appendix E.

The expert groups addressed:

- Gaps in the desirable green infrastructure
- Necessary connective corridors between SCV areas
- Additional roadless and/or insulated areas (i.e., parcels that do not have access or where access has been cut off by streams, landslides, road or railroad construction, or land development actions) that are prime conservation targets
- Lands set aside by private individuals for viewshed protection
- Areas expected to be impacted due to recent development, recreation, infrastructure projects, etc.
- Flood-prone areas
- Areas of high conservation value based on specific features, history, spiritual value, cumulative landscape-wide effects of the ecosystem, etc
- Additional buffer zones
- Changes in the weighting of the initial model output material/maps
- Potential uses of the final product

APPENDIX E: GIS METHODS AND RESULTS

Introduction

Three of the primary objectives of the GWCI GIS project, as stated in the original proposal, are as follows:

1. Identify and categorize existing “open space.”
2. Identify undeveloped lands—not including existing open space—having significant conservation value and rank these areas in terms of relative conservation value (or conservation priority).
3. Identify undeveloped “marginal lands” (eroded, high-runoff) adjacent to or near existing open space and high-priority conservation targets and rank them in terms of their relative potential to negatively impact the quality of existing open space or potential conservation targets.

The GWCI GIS project successfully met objectives 1 and 2. The first geoprocessing model simply identifies and categorizes open space as a single GIS data layer. The second, called the Significant Conservation Value Model, is hierarchical, comprised of multiple geoprocessing models, each targeting a specific analytical variable such as biodiversity.

Objective 3 was excluded from the GWCI GIS project. The consensus of the GIS Steering Committee and the project sponsors was to focus on the Significant Conservation Value model and put it to use before rushing to consider the restoration issue. As the published GIS model and toolset is tuned and applied by project stakeholders to identify conservation targets, it will be very straightforward to identify potential buffer and restoration zones through simple maps and GIS methods.

This appendix summarizes the methods and results of the SCVM. Sections include a description of the SCVM architecture, a synopsis of key GIS analytical concepts, detailed descriptions of the geoprocessing models, maps of the model results, and post-modeling analysis.

SCVM Hierarchical Geoprocessing Model Architecture

The SCVM is a GIS-based hierarchical geoprocessing framework built with ESRI’s ArcView 9.2, the Spatial Analyst extension, and the embedded ModelBuilder component of ESRI’s ArcGIS software line. Geoprocessing models are analytic constructs that provide a flowchart interface for exposing sequences of GIS processes along with explicitly defined analysis parameters. Geoprocessing models are easily modified to incorporate new data and to evaluate different analysis parameters, making them useful tools for long-term planning and research. The geoprocessing model framework is scientifically repeatable and self-documenting; geoprocessing history is stored as metadata.

At the core of the SCVM system is a functionally and thematically organized directory structure for GIS data, ArcMap documents, geoprocessing toolboxes, exported maps, and documentation. The SCVM user interface is an ArcMap document that points to all required model inputs, and a custom toolbox containing several dozen ArcGIS geoprocessing models. The following illustration shows the basic directory structure for inputs, outputs, and other elements of the SCVM.

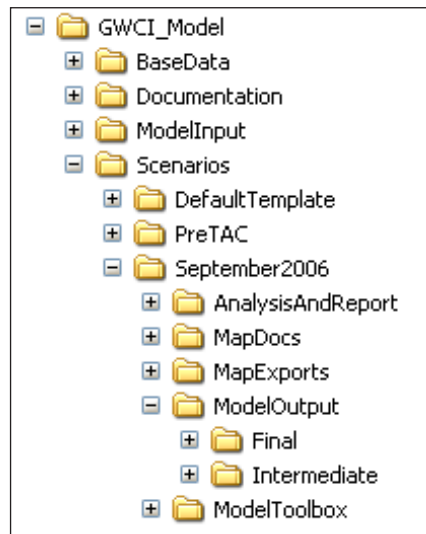

Design Considerations and Configuration Details

The SCVM organizational structure—which includes map documents, toolboxes, models, model inputs, and model outputs—is designed to preserve the default version while at the same time allowing for the exploration of different versions or scenarios. Note that the results presented in this document are based on a “default” version, approved by the GWCI GIS Steering Committee but subject to refinement in the future.

The SCVM structure takes advantage of the relative path references of ArcGIS 9.x map documents, toolboxes, and model outputs, allowing the user to make a copy of the entire default scenario folder. By changing the name of the new scenario folder and renaming the map document and model toolbox contained therein, the user can open the map document, reset the environment settings as necessary, and then manipulate the models as desired. Importantly, this scenario-building effort does not require duplication of the model input data, which is stored in a folder called ModelInput, located at the same directory level as the root scenario folder.

Geoprocessing environment settings control important analysis parameters. In the SCVM, environment settings are configured at the level of the toolbox, simplifying the process of changing default settings (workspace and scratch space locations, output extent, mask, and cell resolution) for the entire hierarchical geoprocessing model. For the published run of the SCVM, the following environment settings were used:

- Current Workspace: the ModelInput subfolder in the statewide directory
- Scratch Space: the ModelOutput\Intermediate subfolder in the statewide directory
- Analysis Extent: Same as the raster “GWCI_Mask”; (HUC12 watershed boundary, buffered by one mile, then rasterized)
- Cell Size: 10 m
- Mask: Same as the raster “GWCI_Mask”

The SCVM toolbox is subdivided into three primary toolsets: one for data preprocessing, one for the hierarchical basin-wide conservation model, and one for post-modeling analysis.

Primary Analytical Concepts

Although the focus of this document is not to provide a comprehensive guide to raster-based GIS analysis and modeling, this section summarizes several very important concepts used throughout this study. A basic understanding of these procedures is necessary to understand and assess the results of the GWCI analysis.

Map Algebra

Map Algebra is the programming language used to run most of the raster functions in the geoprocessing models of the GWCIM. To provide some context, we present the following section from [ESRI's ArcGIS Desktop Help](http://webhelp.esri.com/arcgisdesktop/9.2/index.cfm?TopicName=welcome)¹.

Map Algebra is the analysis language for ArcGIS Spatial Analyst. It is a simple syntax similar to any algebra. An output raster data set will result from manipulation of the input. The input can be as simple as a single raster data set, raster layer, feature data set, feature layer, or shapefile. Manipulation can be done by calculating the sine of each location's values, or there can be a series of input raster data sets or raster layers to which the manipulation is applied, such as when adding three raster data sets or raster layers together. Map Algebra allows you to build

¹<http://webhelp.esri.com/arcgisdesktop/9.2/index.cfm?TopicName=welcome>

complex expressions and process them as a single command. For instance, you can calculate the sine of an input raster data set or raster layer and add it to two other input raster data sets or raster layers.

The Map Algebra language provides building blocks that can be used individually or in conjunction with one another to solve problems. When combining the blocks, a syntax or set of rules must be followed for ArcGIS Spatial Analyst to perform the requested task. The grammar of the language establishes the meaning of the building blocks according to the position of a block in an expression. If type constraints or syntax rules are violated, an error message will be returned, and no result will be created.

The building blocks for the Map Algebra language are objects, actions, and qualifiers on the actions. These delineations are similar to nouns, verbs, and adverbs.

Actions that can be performed on input objects are operators and functions. ArcGIS Spatial Analyst operators perform mathematical computations within and among raster data sets, raster layers, feature data sets, feature layers, tables, numbers, and valid combinations of them all. The set of operators is composed of arithmetical, relational, Boolean, bitwise, and logical operators that support both integer and floating-point values and combinatorial operators, which simultaneously overlay raster data sets or raster layers and maintain the input attributes.

ArcGIS Spatial Analyst functions are spatial cartographic modeling tools that analyze cell-based data. These functions are divided into five categories: local, focal, zonal, global, and application specific. Local functions include trigonometric, exponential, reclassification, selection, and statistical functions. The focal functions provide a set of tools for neighborhood analysis. The zonal functions allow for zonal analysis and computing zonal statistics. The global functions provide tools for full raster layer or raster data set analysis, such as the generation of Euclidean and cost distance rasters. The application functions provide tools that are applicable to specific tasks, such as hydrology, data cleanup, and geometric transformation.

All the values of a raster data set or raster layer can be multiplied or divided by any number, or a number can be added to or subtracted from each value in a raster data set or raster layer. Numbers can be used in most operations on a raster data set, raster layer, or constant. When used in a function, a number can also set a parameter, such as a neighborhood width, the maximum distance to which to calculate the Euclidean distance, or the test for a conditional statement.

Weighted Overlay Analysis

Many of the concepts outlined in this ESRI summary are relevant to the Raster Sum and Weighted Sum Analyses used in the composite models.

To provide the reader with some background on how weighted overlay analysis works, we present the following section from [ESRI's ArcGIS Desktop Help website](#).

Weighted overlay is a technique for applying a common scale of values to diverse and dissimilar input to create an integrated analysis. Geographic problems often require the analysis of many different factors. For instance, choosing the site for a new housing development means assessing such things as land cost, proximity to existing services, slope, and flood frequency. This information exists in different rasters with different value scales: dollars, distances, degrees, and so on. You cannot add a raster of land cost (dollars) to a raster of distance to utilities (meters) and obtain a meaningful result.

Additionally, the factors in your analysis may not be equally important. It may be that the cost of land is more important in choosing a site than the distance to utility lines. How much more important is for you to decide.

Even within a single raster, you must usually prioritize values. Some values in a particular raster may be ideal for your purposes (for example, slopes of 0 to 5 degrees), while others may be good, others bad, and still others unacceptable.

The Weighted Overlay process lets you take all these issues into consideration. It reclassifies values in the input rasters onto a common evaluation scale of suitability or preference, risk, or some similarly unifying scale. The input rasters are weighted by importance and added to produce an output raster.

The steps are summarized below:

- 1. A numeric evaluation scale is chosen. This may be 1 to 5, 1 to 9, or any other scale. Values at one end of the scale represent one extreme of suitability (or other criterion); values at the other end represent the other extreme.*
- 2. The cell values for each input raster in the analysis are assigned values from the evaluation scale and reclassified to these values. This makes it possible to perform arithmetic operations on the rasters that originally held dissimilar types of values.*

3. Each input raster is weighted, or assigned a percent influence based on its importance to the model. The total influence for all rasters equals 100 percent. The cell values of each input raster are multiplied by the rasters' weights. The resulting cell values are added to produce the output raster.



The two input rasters above have been reclassified to an evaluation scale of 1 to 3. Each raster is assigned a percentage influence. The influence of the first raster is 75 percent and the influence of the second is 25 percent. The cell values are multiplied by their influence percentages, then added to create the output raster. Take the top left cell as an example ($2 * .75 = 1.5$ and $3 * .25 = .75$). The sum of 1.5 and .75 is 2.25. Because the output raster is discrete, the value is rounded to 2.

A weighted overlay example

In the following example, a location for a new urban park is being chosen. Three factors will be considered: land use, population density, and distance to existing parks. The goal is to find an area of suitable land use, such as vacant land, in a neighborhood of high population density to provide green space in crowded areas that are not already served by an existing park.



The input rasters to the weighted overlay are displayed in the image above. They are (from left to right): land use, population density, and distance to parks. The weighted overlay model is displayed in the image below as a process in the Model Builder.

Each value class in each input raster is assigned a new (reclassified) value on an evaluation scale of 1 to 5, where 1 represents the lowest suitability and 5 the highest.

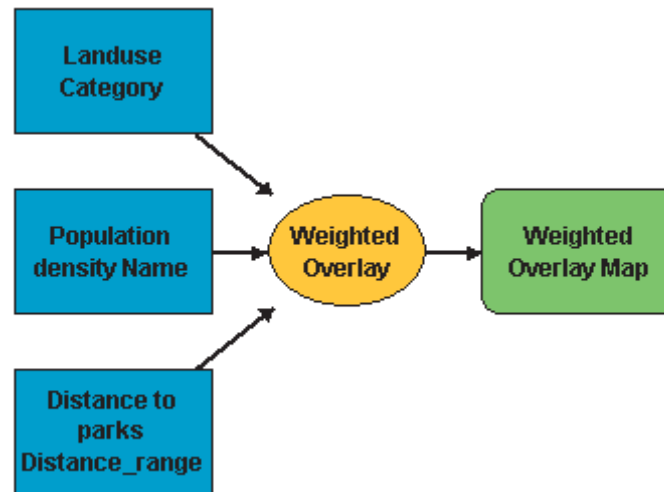

For instance, in the land use raster, vacant land is highly suitable, while commercial land is not. In the population density raster, suitability values are high for high-density areas and low for low-density areas. In the distance to parks raster, suitability increases with distance from existing parks because areas far from existing parks are inadequately served.

Any class can also be assigned a restricted value, which means that the corresponding area is unacceptable or cannot be used. Restricted areas are excluded from the analysis. In the land use raster, for example, airports and water bodies are restricted.

Each of the three input rasters is then weighted. In this weighted overlay, land use has a 50 percent influence, population density a 15 percent influence, and distance from parks a 35 percent influence. When the weighted overlay is run, a raster of overall suitability is created.

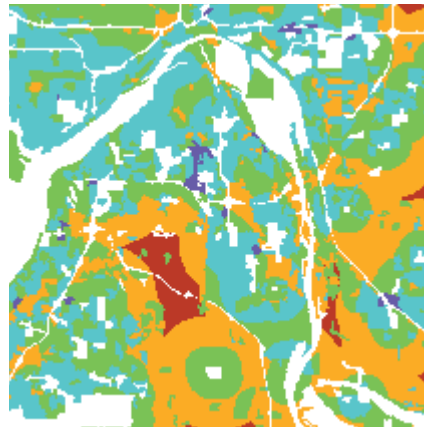

The most suitable areas are shown in red. Orange areas are next, followed by green. Blue and purple areas are least suitable, and white areas are restricted. Modifying the suitability values or the influence percentages will produce different results.

Sum

In the GWCIM, the sum function is used to combine the composite models for each major SCV category (e.g., Scenic Value) through an additive process, forming an output comprised of values derived from the sum of overlapping cell values. The following definition and graphic example comes directly from the ArcGIS 9.2 Desktop Help.

Outputs the sum of all input values on a cell-by-cell basis within the Analysis window.

Weighted Sum

The weighted sum function combines aspects of the weighted overlay analysis with the sum function. Basically, overlapping cell values are summed *after* any weighting (multiplication by a factor) is applied to specific layers. This method allows one to modify the relative contribution of input rasters. For example, one might multiply a raster of cultural resource value by two and then sum that result with the unweighted output from the scenic value raster.

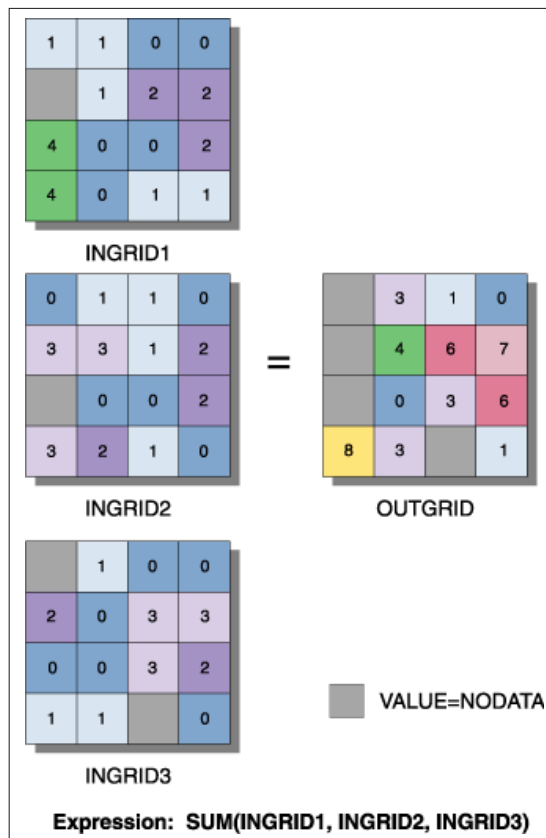

Zonal Statistics

To provide the reader with some background on how Zonal Statistics works, we present the following section from ESRI's ArcGIS Desktop Help.

With Zonal Statistics, a statistic is calculated for each zone defined by a zone data set, based on values from another data set (a value raster). A zone is all the cells in a raster that have the same value, regardless of whether or not they are contiguous. However, both raster and feature data sets can be used as the zone data set. So, for example, residential is a zone of a land use raster data set, or roads feature data set can be the zone for an accident data set. Zonal statistical functions perform operations on a per-zone basis; a single output value is computed for every zone in the input zone data set.

The Zone layer defines the zones (shape, values, and locations). The Value raster contains the input values used in calculating the output for each zone. The Input zone layer is a field that can be added to the zone layer attribute table containing the statistics calculated for each zone. The following statistics can be computed within each zone:

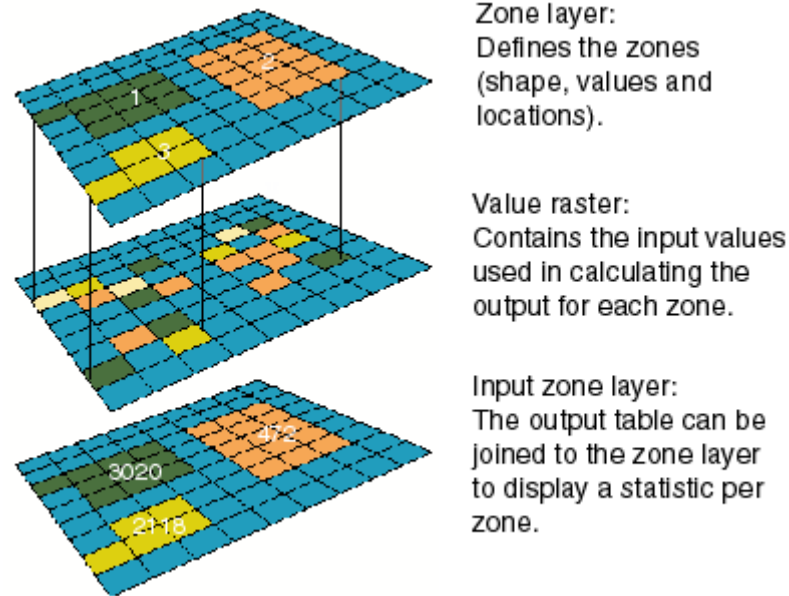

Majority: Determines the value that occurs most often in the zone

Maximum: Determines the maximum value in the zone

Mean: Computes the mean of the values in the zone

Median: Computes the median of the values in the zone

Minimum: Determines the minimum value in the zone

Minority: Determines the value that occurs least often in the zone

Range: Determines the range of values in the zone

Standard Deviation: Computes the standard deviation of the values in the zone

Sum: Computes the sum of the values in the zone

Variety: Determines the number of different values within the zone

Zonal Majority Example:

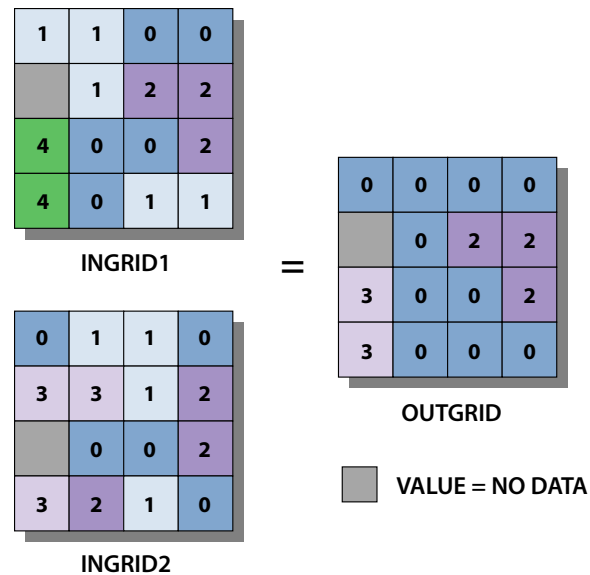

Expression: ZONALMAJORITY (INGRID1, INGRID2)

SCVM Analysis Criteria and Key Parameters

The SCVM hierarchy consists of four primary geoprocessing models—flowchart-like analytic constructs—called Composite Models:

- Scenic Value
- Cultural Resources Value
- Habitat Value
- Water Value

Composite Models (e.g., overall habitat value) combine the results of two or more secondary geoprocessing models called Component Models (e.g., animal species diversity, low road-density grasslands).

The sequence of model implementation for a given thematic category such as scenic value is simple: All Component Models are run first, followed by the Composite Model. The results of the four Composite Models are combined in the SCV Wrap-up Model. The Component Models and the SCV Wrap-up Models generate two raster outputs, one based on a simple sum operation and another based on a weighted sum operation that also reclassifies results into three ordinal classes. These GIS functions are described above in the Analytic Concepts.

Note that for the current analysis, equal weights were applied to all input criteria for all models. In the future, these weights can be adjusted on the fly for use in evaluating different funding and conservation priority scenarios.

While the SCV Wrap-up is perhaps most important, each individual Composite Model can be assessed and utilized independently. Importantly, note that these models can be adjusted in many ways, from the vintage or accuracy of input data sets to the classification schemes and parameter settings (e.g., buffer distance, richness value threshold).

The following graphic shows the SCVM toolbox.

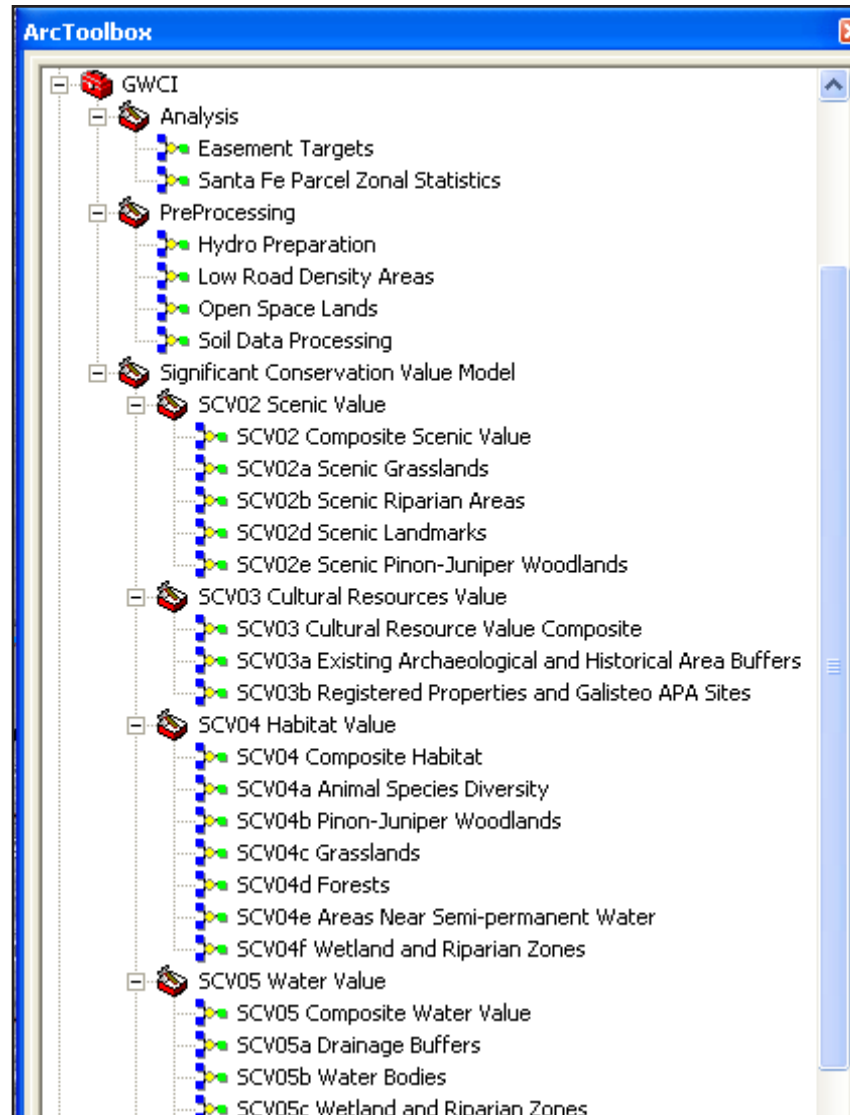

SCVM Model Criteria

Metadata, Model Descriptions, Weighting Criteria, and Other Information

Model SCV2: Scenic Value

Composite Model Weighting	Component Models	Secondary Model Ranking Strategy	Component Model Weighting	Output Data set Name	Metadata	Model Summary
25.00%	Scenic grasslands	SCV Score = 1 Other Lands, SCV Score = 0	25%	SCV02a	NLCD 2002 data set	This model selects zones defined as grasslands in the New Mexico GAP vegetation data set, removing zones classified as developed/disturbed in the NLCD 2002 land use data set. The output raster assigns a value of 1 to scenic (undeveloped) grasslands and 0 to all other areas.
	Scenic riparian areas	SCV Score = 1 Other Lands, SCV Score = 0	25%	SCV02b	Contact Jan-Willem Jansens for more information on the EWI projects.	This model converts wetland and riparian vegetation polygons collected with sub-meter GPS equipment during the Earth Works Institute (EWI) Riparian Vegetation Inventory Project (2002) and the EWI Galisteo Wetlands Project inventory (2006) into raster format. In the output raster, wetlands and riparian areas are assigned a value of 1 and all other areas are assigned a value of 0.
	Scenic piñon-juniper areas	SCV Score = 1 Other Lands, SCV Score = 0	25%	SCV02e		This model selects zones defined as piñon-juniper woodlands in the New Mexico GAP vegetation data set, removing zones classified as developed/disturbed in the NLCD 2002 landuse data set. The output raster assigns a value of 1 to scenic (undeveloped) piñon-juniper woodlands and 0 to all other areas.
	Scenic landmark areas	SCV Score = 1 Other Lands, SCV Score = 0	25%	SCV02d		This model creates a binary raster in which scenic landmarks and areas have a value of 1 and all other areas have a value of 0. The input data for this model comes from a variety of reference sources and is based on a qualitative assessment of what is scenic made by members of the GWCI Scenic Areas Technical Advisory Group (TAC/Delphi). Features were extracted using topographic maps, the GNIS (Geographic Named Information System) database, 10m dem-based maps of relief/slope, Teletlas transportation data, and other data sources.
					Model SCV02 Composite	All SCV02 component models

Model SCV3: Cultural Resources Value

Composite Model Weighting	Component Models	Secondary Model Ranking Strategy	Component Model Weighting	Output Data set Name	Metadata	Model Summary
25.00%	Buffered locations of recorded archaeological or historical sites of demonstrated or potential significance	Proximity: within 100 m site buffer, SCV Score = 1 Other areas, SCV Score = 0	50.00%	SCV03a	The inputs to this model include data from New Mexico's Archaeological Records Management System (ARMS), historic trails digitized from 1:24k USGS topo maps, railroads extracted from high-resolution Teleatlas street data, and points/areas delineated by members of the Cultural Resources/Historic TAC/Delphi group.	This model takes four categories of archaeological/historical features, buffers each based on data-specific parameters, merges them together, and then creates an output raster in which cells within 200m of the buffered locales are assigned a value of 1. All other areas are assigned a value of 0 in the output raster.
	Buffered areas and sites that currently are (1) listed on the National Register of Historic Places or the State Register of Cultural Places, and/or (2) identified as a target for preservation in the Galisteo Basin Archaeological Sites Protection Act.	Presence, within designated sensitivity zone, SCV Score = 1, Other areas, SCV Score = 0	50.00%	SCV03b		In this model, lands that are (1) currently listed on the National Register of Historic Places or the State Register of Cultural Places, and/or (2) identified as a target for preservation in the Galisteo Basin Archaeological Sites Protection Act, are rasterized, and cells within the sensitive areas are assigned a score of 1. All other cells are assigned a score of 0.
				Model SCV03 Composite	SCV03d	The composite Cultural Resources Value Model combines the component models in two ways, one based on the sum of input rasters and the other based on a weighted sum process. The unweighted sum of the three Scenic Value Component Model rasters results in a layer with values ranging from a minimum of 0 to a maximum of 3. The weighted sum process reclassifies positive output values into three classes of conservation value: moderate, high, very high. Note that for the published release of the GWCI Model, all Cultural Resources Value component models were assigned equal weights in the weighted sum analysis.

Model SCV4: Habitat Value

Composite Model Weighting	Component Models	Secondary Model Ranking Strategy	Component Model Weighting	Output Data set Name	Metadata	Model Summary
25.00%	Presence of high species biodiversity	Presence: SCV Score = 1 Other Lands, SCV Score = 0	20.00%	SCV04a	The richness data used in this model are derived from the 1996 NM GAP vegetation analysis. For more information, refer to the GAP final report and the individual metadata reports for the richness studies in the GWCI metadata folder. A summary of the final report is available online at http://www.gap.uidaho.edu/bulletins/6/FRSNMGAP.htm	This model uses the GAP richness analysis result data for each vegetation class represented in the GAP vegetation data set to generate a raster with three ordinal classes of overall species diversity (low, medium, and high). Given the binary nature of the April 2006 GWCI model run, this variability is parsed into only two classes: high-diversity areas, determined by an arbitrary break in richness, are assigned a final output score of 1 and other zones are assigned the value of 0.
	Presence TES species	Not used in April 2006 GWCI model run due to coarseness of locational data obtained from the NM Natural Heritage Program. We have only the names of 7,5 minute USGS quads in which specific T and E species have been documented. We could use these data, should stakeholders determine this level of locational accuracy is sufficient.				If this model were to be run, we likely would assign all areas within USGS quads having documented T and E species the value of 1 and all other areas would get a value of 0.
	Presence of low-road-density grasslands	Presence: SCV Score = 1 Other Lands, SCV Score = 0	20.00%	SCV04c	Model inputs consist of the 1996 NM GAP vegetation analysis and the 2002 National Land Cover Data set (NLCD). For more information on the GAP data set, refer to the GAP final report and the individual metadata reports for the richness studies in the GWCI metadata folder. A summary of the GAP final report is available online at http://www.gap.uidaho.edu/bulletins/6/FRSNMGAP.htm . For information on the NLCD data set, see the following: ftp://edcftp.cr.usgs.gov/pub/data/landcover/states/new_mexico_FGDC.txt	This model selects grassland areas from the New Mexico GAP vegetation analysis, removes developed areas (e.g., high-density residential) indicated by the 2002 National Land Cover Data set, and then ranks the relative health of undeveloped grasslands using NDVI values from MODIS 1 km data. Importantly, the threshold for determining what is “high quality” (greener) is arbitrarily set at 2200 in the April 2006 GWCI model run. Input from experts as to where to set this threshold would improve the validity of the output from this model. Several other ideas for improving this model include: (1) using NDVI derived from 15 m landsat data (rather than 1 km MODIS data) and (2) using two sets of landsat data — from very dry and very wet years, respectively — subtracting the dry year NDVI values from the wet year NDVI values and then targeting the areas of greatest difference. Those areas of greatest difference in NDVI are zones with high potential for restoration/improvement.

Model SCV4: Habitat Value, *continued*

Composite Model Weighting	Component Models	Secondary Model Ranking Strategy	Component Model Weighting	Output Data set Name	Metadata	Model Summary
	Presence of low-road-density forests	Presence: SCV Score = 1 Other Lands, SCV Score = 0	20.00%	SCV04d	Model inputs consist of the 1996 NM GAP vegetation analysis and the 2002 National Land Cover Data set (NLCD). For more information on the GAP data set, refer to the GAP final report and the individual metadata reports for the richness studies in the GWCI metadata folder. A summary of the GAP final report is available online at http://www.gap.uidaho.edu/bulletins/6/FRSNMGAP.htm . For information on the NLCD data set, see the following: ftp://edcftp.cr.usgs.gov/pub/data/landcover/states/new_mexico_FGDC.txt	This model selects forested areas from the New Mexico GAP Vegetation Analysis, removes developed areas (e.g., high-density residential) indicated by the 2002 National Land Cover Data set, and then ranks the relative health of undeveloped forests using NDVI values from MODIS 1 km data. Importantly, the threshold for determining what is “high quality” (greener) is arbitrarily set at 2300 in the April 2006 GWCI model run. Input from experts as to where to set this threshold would improve the validity of the output from this model. Several other ideas for improving this model include: (1) using NDVI derived from 15 m landsat data (rather than 1 km MODIS data) and (2) using two sets of landsat data — from very dry and very wet years, respectively — subtracting the dry year NDVI values from the wet year NDVI values and then targeting the areas of greatest difference. Those areas of greatest difference in NDVI are zones with high potential for restoration/improvement.
	Presence of riparian vegetation and wetlands	Presence: SCV Score = 1 Other Lands, SCV Score = 0	20.00%	SCV04f	This model is simply a copy of the output from SCV05c. See the metadata for that output layer and model.	This model is simply a copy of the output from SCV05c. See the metadata for that output layer and model.
	Presence of semi-permanent water (excluding wetlands)	Presence: SCV Score = 1 Other Lands, SCV Score = 0	20.00%	SCV04e	Model SCV05a, b, and d	This model is a composite of three component models in the Water Value Model: SCV05a (presence of drainages), SCV05b (presence of water bodies) and SCV05d (presence of springs). These “wet” areas are assigned a value of 1 and all other areas are assigned a value of 0. We might consider adding dirt tanks and watering facilities (rain feeders) to the inputs for this model as these are additional sources of semi-permanent water.

Model SCV4: Habitat Value, *continued*

Composite Model Weighting	Component Models	Secondary Model Ranking Strategy	Component Model Weighting	Output Data set Name	Metadata	Model Summary
			100%	Model SCV04 Composite	All SCV04 component models	<p>The composite Habitat Value Model combines the component models in two ways, one based on the sum of input rasters and the other based on a weighted sum process. The unweighted sum of the five Scenic Value Component Model rasters results in a layer with values ranging from a minimum of 0 to a maximum of 5. The weighted sum process reclassifies positive output values into three classes of conservation value: moderate, high, very high. Note that for the published release of the GWCI Model, all Habitat Quality component models were assigned equal weights in the weighted sum analysis.</p>

Model SCV5: Water Value

Composite Model Weighting	Component Models	Secondary Model Ranking Strategy	Component Model Weighting	Output Data set Name	Metadata	Model Summary
25.00%	Presence of major drainages	Proximity: Galisteo Creek, NE Segment (above Cañoncito): 0 to 50 m, SCV Score = 1; Galisteo Creek, Cerrillos to Cañoncito: 0 to 50 m, SCV Score = 1; First Order Tributaries to Galisteo Creek: 0 to 25 m, SCV Score = 1; Second Order Tributaries to Galisteo Creek: 0 to 20 m, SCV Score = 1; Third Order Tributaries to Galisteo Creek: 0 to 10, SCV Score = 1; Other drainages, SCV Score = 0	20%	SCV05a	This model uses the “medium resolution” (1:100,000) scale National Hydrographic Data set. See www.nhd.gov	Using the NHD vectors and their associated stream level attributes, drainages are selected and buffered in a raster environment as follows: Galisteo Creek, NE Segment (above Cañoncito), 0 to 50 m, SCV Score = 1; Galisteo Creek, Cerrillos to Cañoncito, 0 to 50 m, SCV Score = 1; First Order Tributaries to Galisteo Creek, 0 to 25 m, SCV Score = 1; Second Order Tributaries to Galisteo Creek, 0 to 20 m, SCV Score = 1; Third Order Tributaries to Galisteo Creek, 0 to 10, SCV Score = 1; Other drainages, SCV Score = 0. The 1:24,000 scale version of the NHD was released shortly after the model was originally created. Unfortunately, the stream level attribute of the higher resolution data set is not populated at this time. This attribute is necessary to automate the buffering thresholds specified by the model.
	Presence of waterbodies	Presence: Waterbodies, SCV Score = 1 Other Lands, SCV Score = 0	20%	SCV05b	This model uses the “medium resolution” (1:100,000) scale National Hydrographic Data set. See www.nhd.gov	This model uses data from the 1:24,000 scale National Hydrographic Data set, as well as ponds from two Earth Works Institute projects: the 2002 EWI Ranch Riparian Vegetation Inventory and the 2006 Galisteo Wetlands Project. This model converts waterbodies into raster cells with a value of 1. All other cells in the output raster get values of 0.

Model SCV5: Water Value, *continued*

Composite Model Weighting	Component Models	Secondary Model Ranking Strategy	Component Model Weighting	Output Data set Name	Metadata	Model Summary
	Presence of wetlands	Presence: Wetland Areas, SCV Score = 1 Other Lands, SCV Score = 0	20%	SCV05c	Three data sets are inputs to this model. Two of the data sets are GPS-based inventories of selected wetlands in the basin: GPS-based (GeoXT, sub-meter) data from 2005-2006 Galisteo Wetland Project and GPS-based (Geo-Explorer 3; 1-3 m) data from the 2004 Earth Works Institute Ranch vegetation study. The third data set consists of probable riparian areas digitized from topos and aerial photos for an infiltration/runoff model created by EWI and Earth Analytic, Inc. in 2004-2005.	The three input data sets are merged into a single layer, converted into a raster. Areas designated as wetlands or riparian areas are assigned a value of 1 and all other areas get values of 0. Importantly, improvements to this model might include ranking different wetland areas, QC and edit of the hand-digitized data, and use of a buffer zone around wetlands to expand the high conservation value envelope for these dynamic features.
	Presence of springs	Presence: Springs, SCV Score = 1 Other Lands, SCV Score = 0	20%	SCV05d	This model uses the "high res" (1:24,000) scale National Hydrographic Data set. See www.nhd.gov	Using the nodes from the 1:24,000 NHD data set, the raster created by this model creates 35 m buffers around springs to cover potential spatial error. Cells within the buffer zone are assigned values of 1 and all other cells get values of 0.
	Presence of aquifer recharge zones	Presence: within zones of potential recharge, SCV Score = 1	20%	SCV05e	The Digital Geologic Map of New Mexico in ARC/INFO Format by Gregory N. Green and Glenn E. Jones http://rgisedac.unm.edu/metadata/geology/geo0004.txt	This model rasterizes polygons representing (1) quaternary alluvium (NM Surface Geology, 1:500,000) and (2) soils (SSURGO, including pre-release data for Santa Fe County) classified as excessively or somewhat excessively drained, assigning a value of 1 to these potential surface recharge deposit areas.

Model SCV5: Water Value, *continued*

Composite Model Weighting	Component Models	Secondary Model Ranking Strategy	Component Model Weighting	Output Data set Name	Metadata	Model Summary
			100%	Model SCV05 Composite		The composite Water Value Model combines the component models in two ways, one based on the sum of input rasters and the other based on a weighted sum process. The unweighted sum of the five Water Value Component Model rasters results in a layer with values ranging from a minimum 0 to a maximum of 5. The weighted sum process reclassifies positive output values into three classes of conservation value: moderate, high, very high. Note that for the published release of the GWCI Model, all Habitat Value Component Models were assigned equal weights in the weighted sum analysis.
						This model uses the weighted sum output from the Significant Conservation Value Wrap-Up Model as the basis for identifying parcels intersected by contiguous one-acre-plus zones of maximum conservation value (Very High, 3). More specifically, the model selects cells classified as "Very High" from the weighted sum output from the Wrap-Up model, defines contiguous blocks of these cells, then further subdivides the output into contiguous blocks of high scoring cells using the region group and zonal geometry functions. Finally, the model runs zonal statistics on the intermediate output with the parcel data set, identifying parcels that intersect these contiguous blocks of high scoring cells.
						This analysis model calculates zonal statistics for each output from each Composite and Wrap-up Model, using the Santa Fe County Parcel layer (09/2006) as the zone data set. To capture a summary of statistics for each parcel, the unique ID field called PRCS-FCO_ was used in the zonal statistics tool. A separate table is generated for each model output. The statistics summarize model scores for each parcel based on the number of cells of each unique value that fall within a given parcel.

SCVM Data Preprocessing Model Descriptions

Hydro Data Processing

This model combines data sets from three high-resolution NHD geodatabases (13020201, 13050001, 13060001) that overlap the Galisteo Basin. The merged drainage, waterbody and spring data sets that occur within the HUC12 catchments comprising the Galisteo Basin are selected and merged into three output data sets.

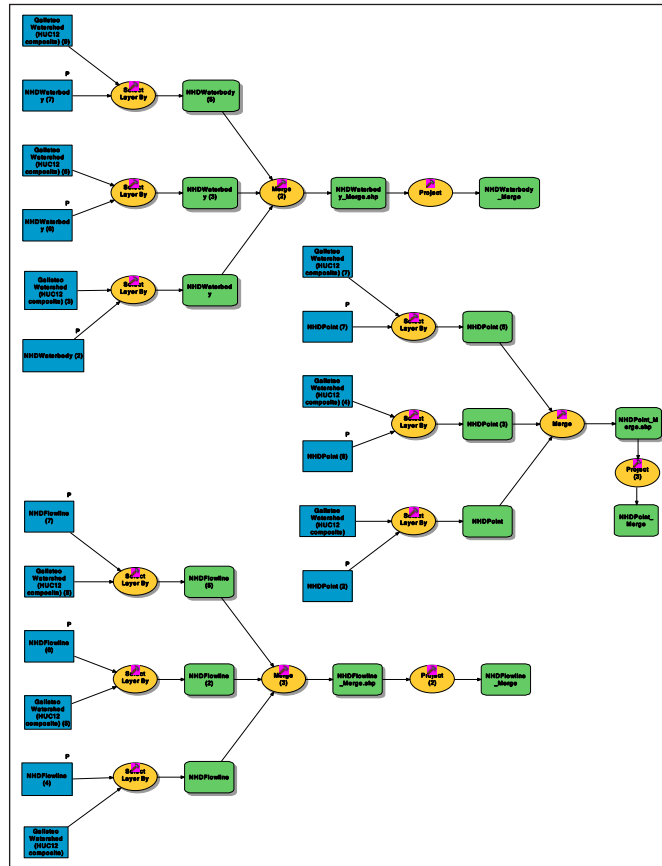

Low Road-Density Areas

Assigns value of 1 to cells falling within square-mile blocks that have less than one linear mile of paved roads.

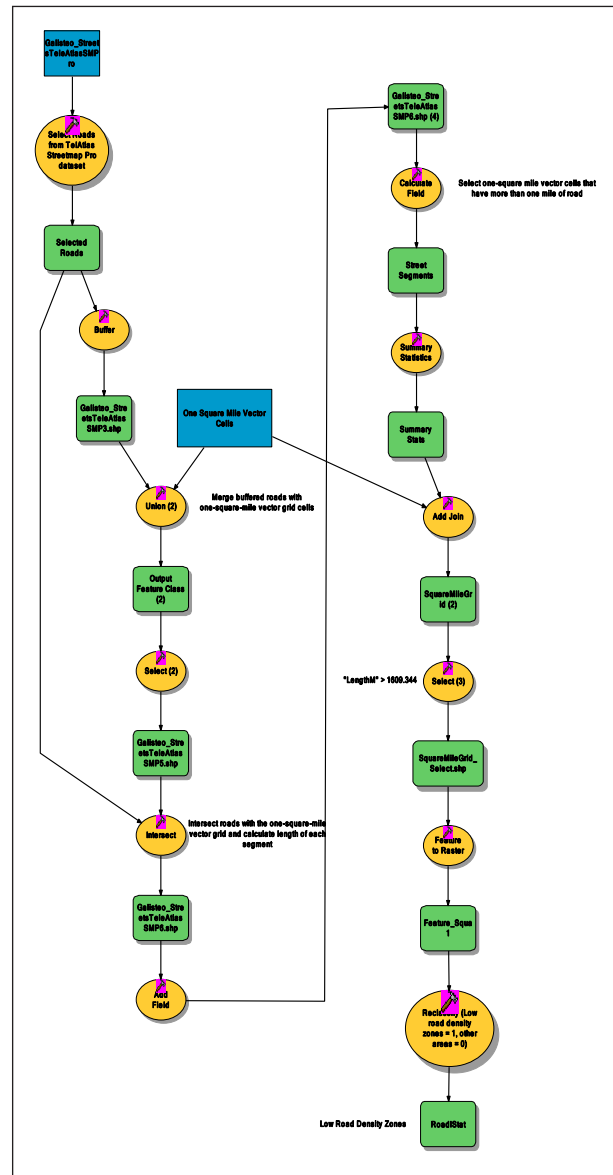

Open Space Model

This model generates a polygon data set comprised of conservation easements held by the Santa Fe Conservation Trust and The Nature Conservancy, parcels in the Santa Fe County database classified as (or known to be) one of the following: common area, park, trail, open space, conservation easement (Eldorado Community Preserve).

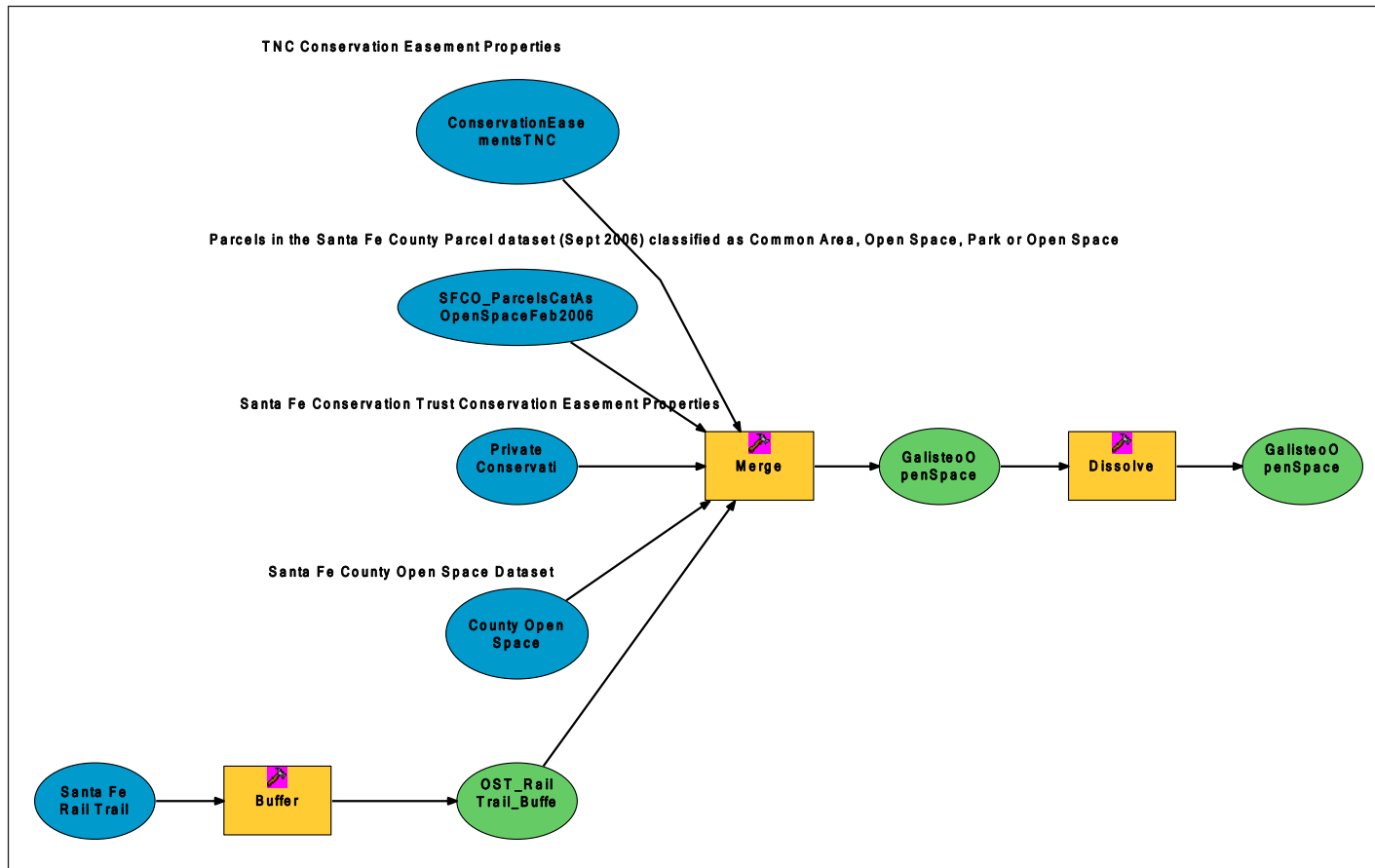

Soil Data Processing

Taking three SSURGO data sets as inputs (San Miguel County, Sandoval County, and Santa Fe County), this model selects soil map unit polygons that fall within the project area and merges them into a single data set for use in other models. The first step of this process entails the joining of the “MUAGGATT” table (from the SSURGO database) to each input data set.

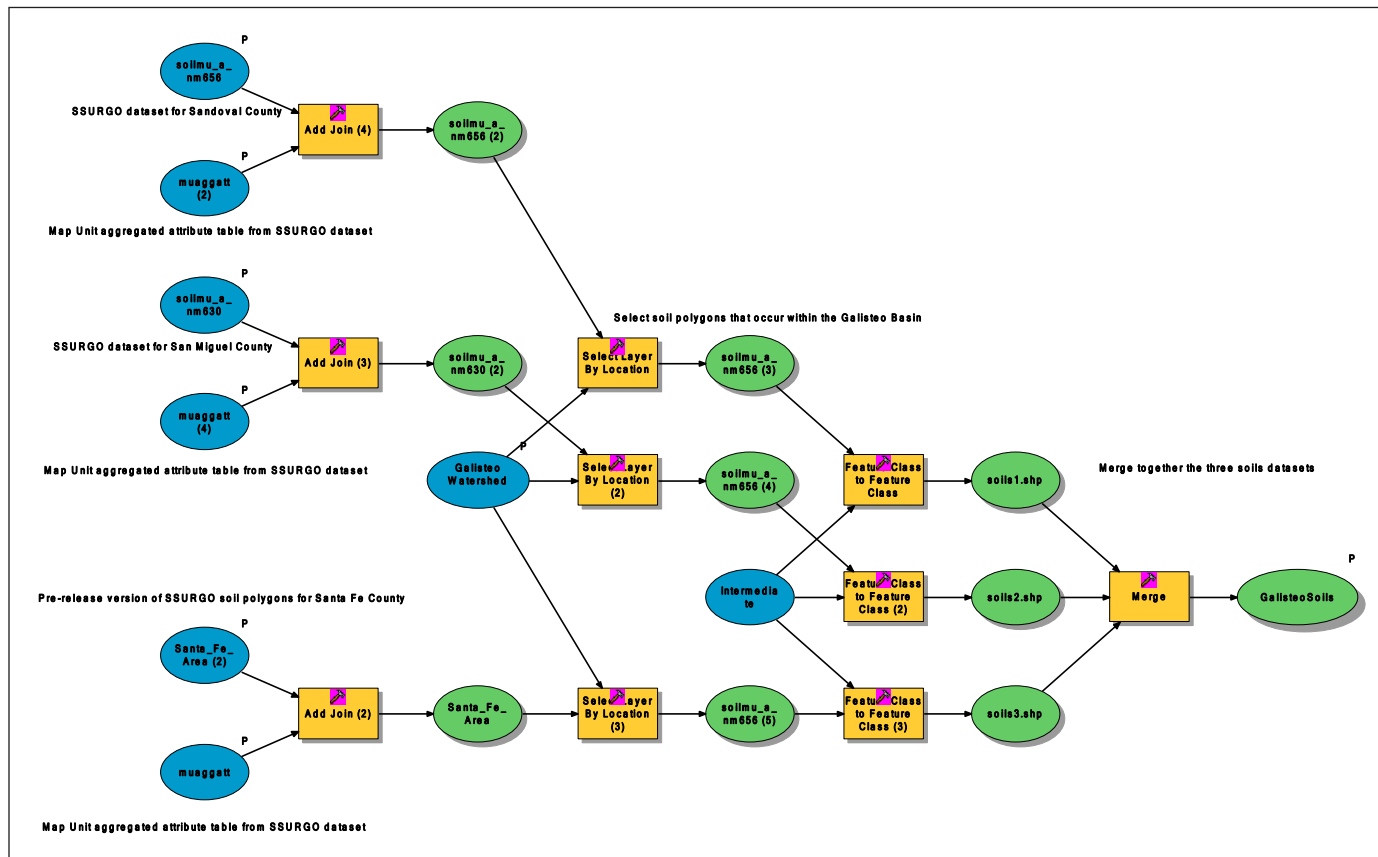

SCVM Model Descriptions

Scenic Value Model (SCV02)

Model SCV02a: Scenic Grasslands

This model selects zones defined as grasslands in the New Mexico GAP vegetation data set, removing zones classified as developed/disturbed in the NLCD 2002 landuse data set. The output raster assigns a value of 1 to scenic (undeveloped) grasslands and 0 to all other areas.

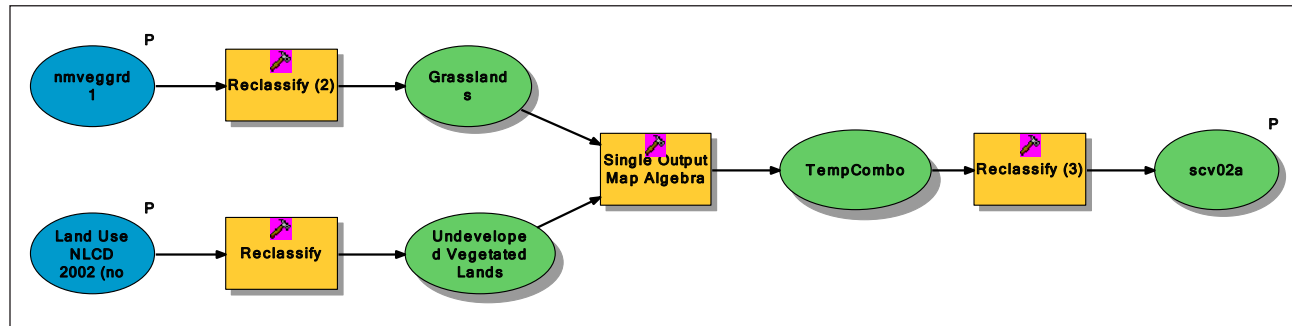

Model SCV02b: Scenic Riparian Areas

This model converts wetland and riparian vegetation polygons collected with sub-meter GPS equipment during the Earth Works Institute (EWI) Galisteo Wetlands Project inventory (2006) into raster format. In the output raster, wetlands and riparian areas are assigned a value of 1 and all other areas are assigned a value of 0.

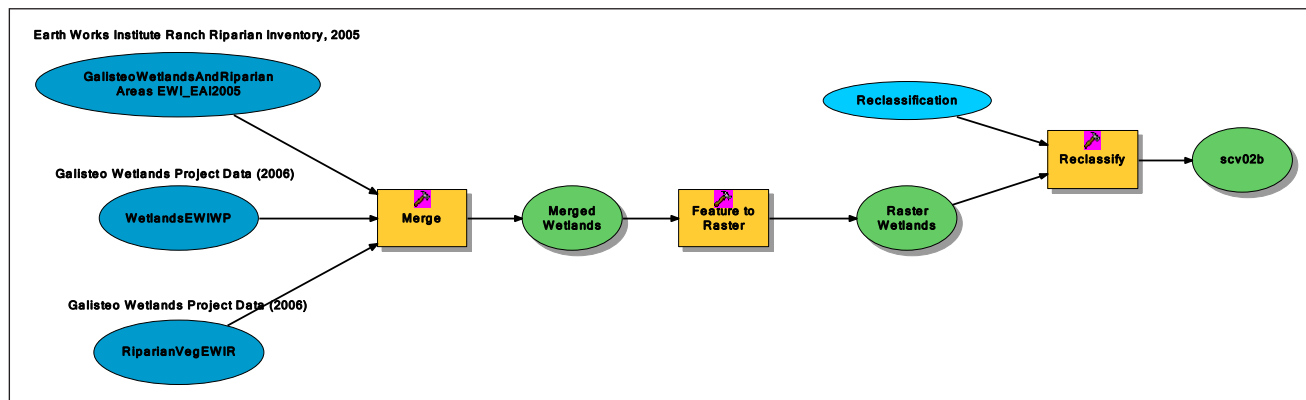

Model SCV02d: Scenic Landmarks

This model creates a binary raster in which scenic landmarks and areas have a value of 1 and all other areas have a value of 0. The input data for this model comes from a variety of reference sources and is based on a qualitative assessment of what is scenic made by members of the GWCI scenic areas technical advisory group (TAC). Features were extracted using topographic maps, the GNIS (Geographic Named Information System) database, 10m dem-based masks of relief/slope, TeleAtlas transportation data, and other data sources.

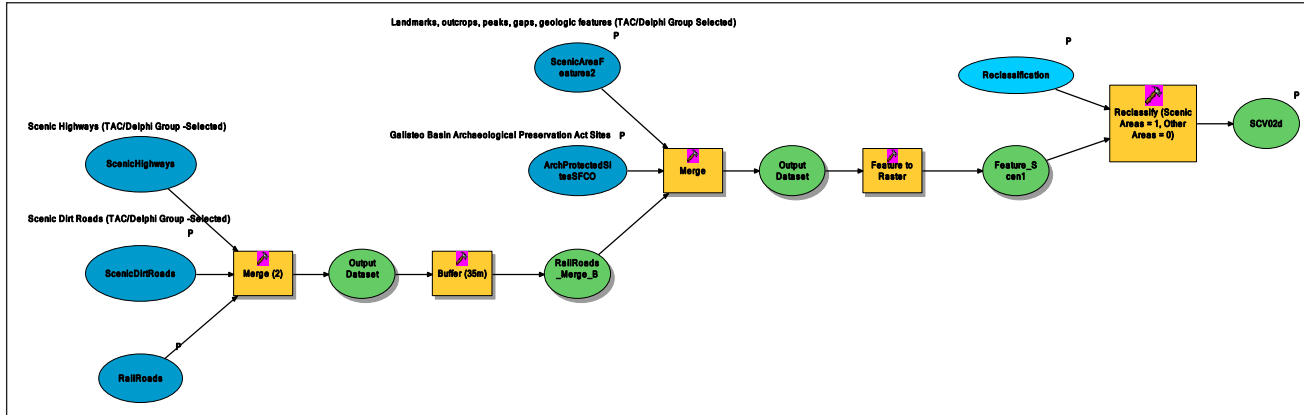

Model SCV02e: Scenic Piñon-Juniper Woodlands

This model selects zones defined as piñon-juniper woodlands in the New Mexico GAP vegetation data set, removing zones classified as developed/disturbed in the NLCD 2002 landuse data set. The output raster assigns a value of 1 to scenic (undeveloped) piñon-juniper woodlands and 0 to all other areas.

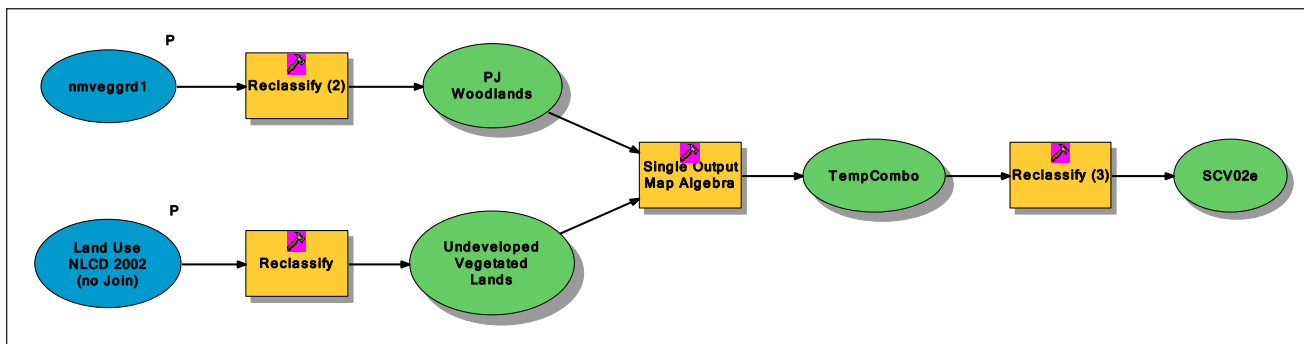

Model SCV02: Composite Scenic Value Model

The composite Scenic Value Model combines the component models in two ways, one based on the sum of input rasters and the other based on a weighted sum process. The unweighted sum of all of the four scenic value rasters results in a layer with values ranging from a minimum of 0 to a maximum of 4. The weighted sum process reclassifies positive output values into three classes of conservation value: moderate, high, very high. Note that for the published release of the GWCI Model, all Scenic Value Component Models were assigned equal weights in the weighted sum analysis.

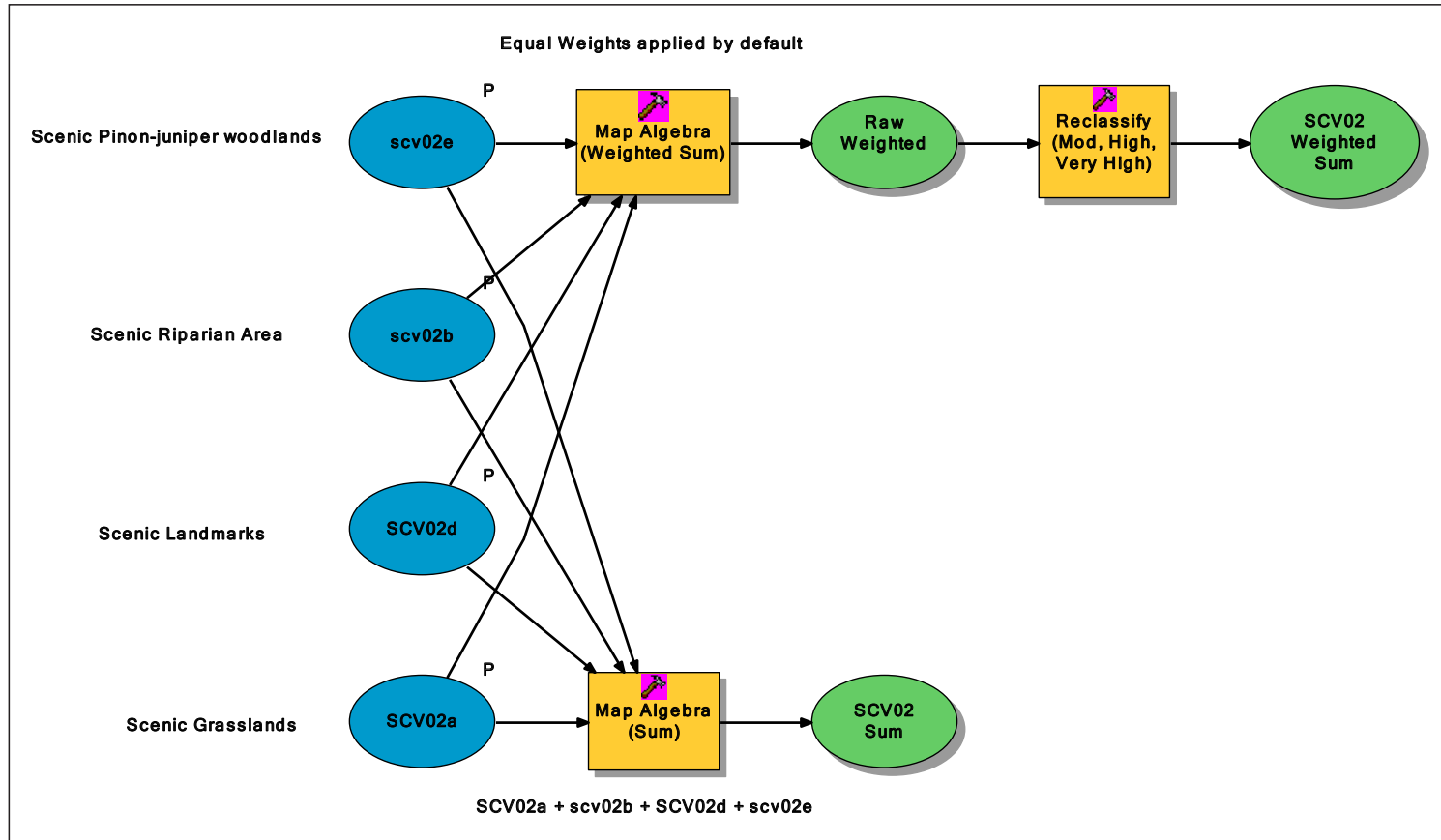

Cultural Resources Value Model (SCV03)

Model SCV03a: Existing Archaeological and Historical Area Buffers

This model takes four categories of archaeological/historical features, buffers each based on data-specific parameters, merges them together, then creates an output raster in which cells within 200m of the buffered locales are assigned a value of 1. All other areas are assigned a value of 0 in the output raster.

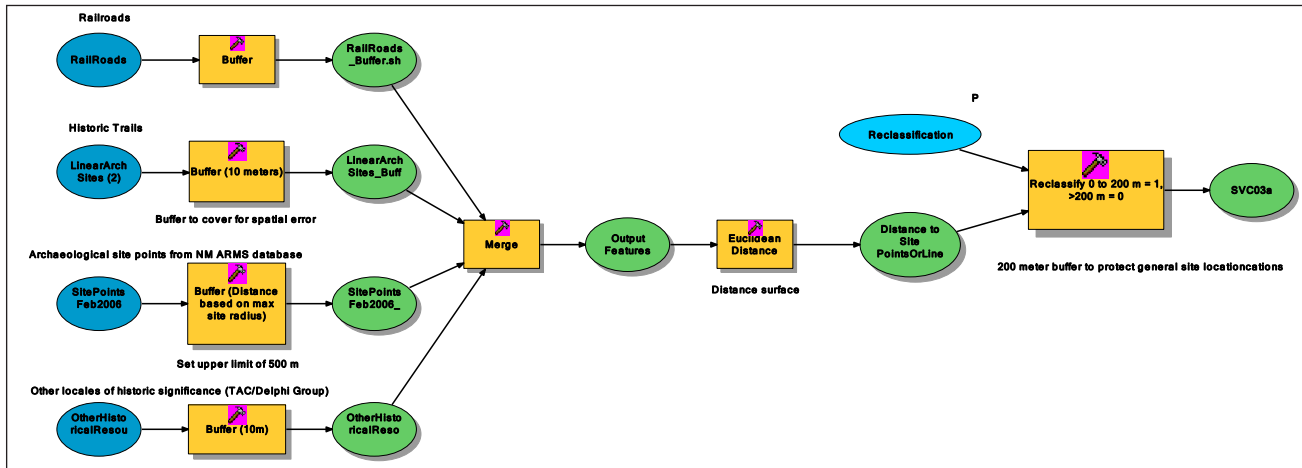

Model SCV03b: Registered Properties and Galisteo APA Sites

In this model, lands that are (1) currently listed on the National Register of Historic Places or the State Register of Cultural Places and/or (2) identified as a target for preservation in the Galisteo Basin Archaeological Sites Protection Act, are rasterized and cells within the sensitive areas are assigned a score of 1. All other cells are assigned a score of 0.

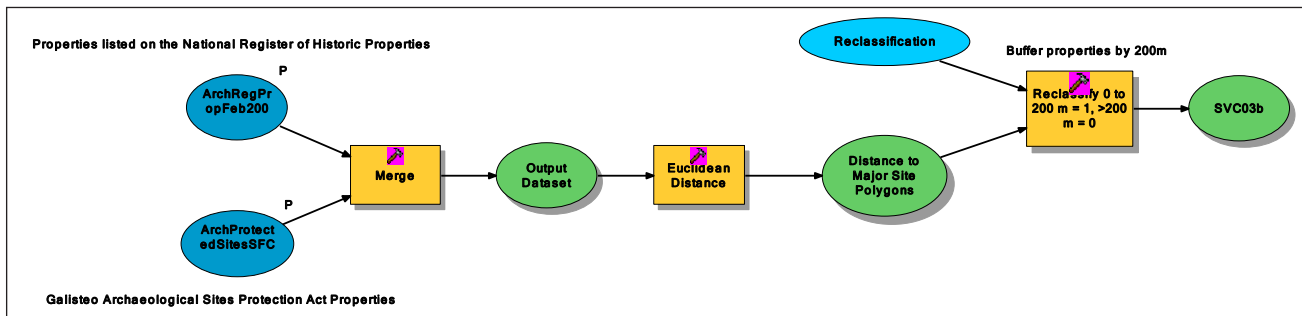

Model SCV03: Cultural Resources Value Composite

The composite Cultural Resources Value Model combines the component models in two ways, one based on the sum of input rasters and the other based on a weighted sum process. The unweighted sum of the three Scenic Value Component Model rasters results in a layer with values ranging from a minimum of 0 to a maximum of 3. The weighted sum process reclassifies positive output values into three classes of conservation value: moderate, high, very high. Note that for the published release of the GWCI Model, all Cultural Resources Value component models were assigned equal weights in the weighted sum analysis.

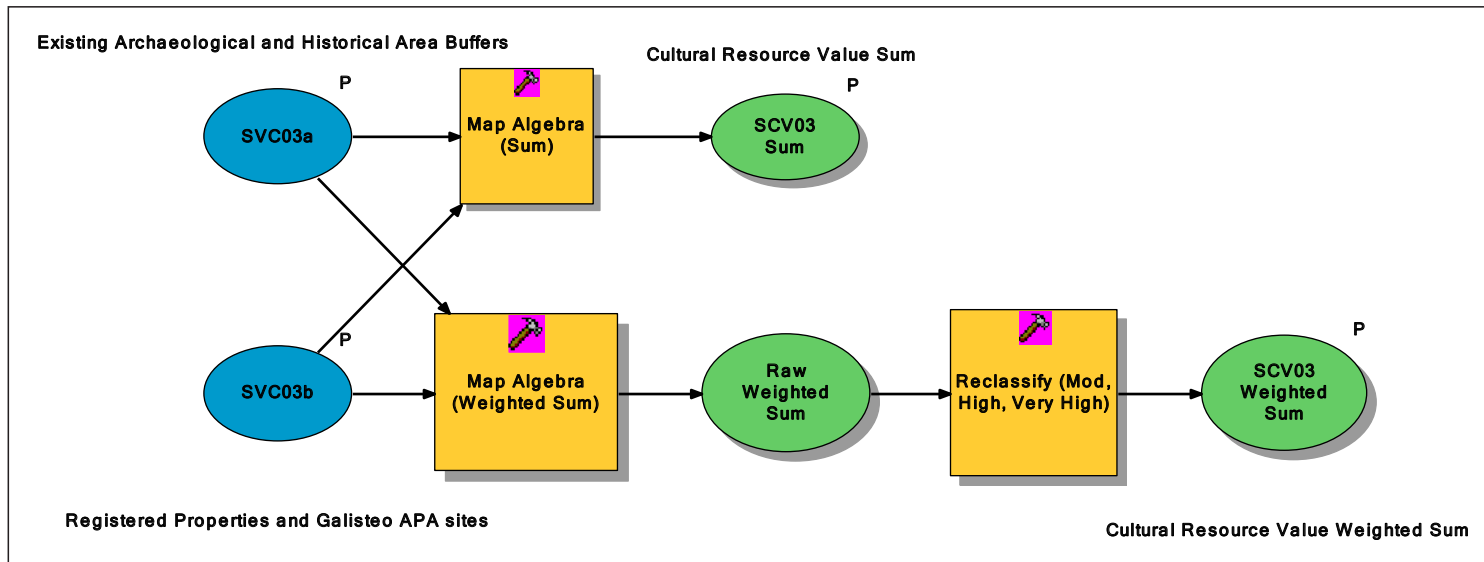

SCV04 Habitat Value

Model SCV04a: Animal Species Diversity

This model uses the gap richness analysis result data for each vegetation class represented in the GAP vegetation data set to generate a raster with three ordinal classes of overall species diversity (low, medium, and high). Given the binary nature of the April 2006 GWCI model run, this variability is parsed into only two classes: high diversity areas, determined by an arbitrary break in richness, are assigned a final output score of 1, and other zones are assigned the value of 0. The richness data used in this model are derived from the 1996 NM GAP vegetation analysis. For more information, refer to the GAP final report and the individual metadata reports for the richness studies in the GWCI metadata folder. A summary of the final report is available online at <http://www.gap.uidaho.edu/bulletins/6/FRSNMGAP.htm>

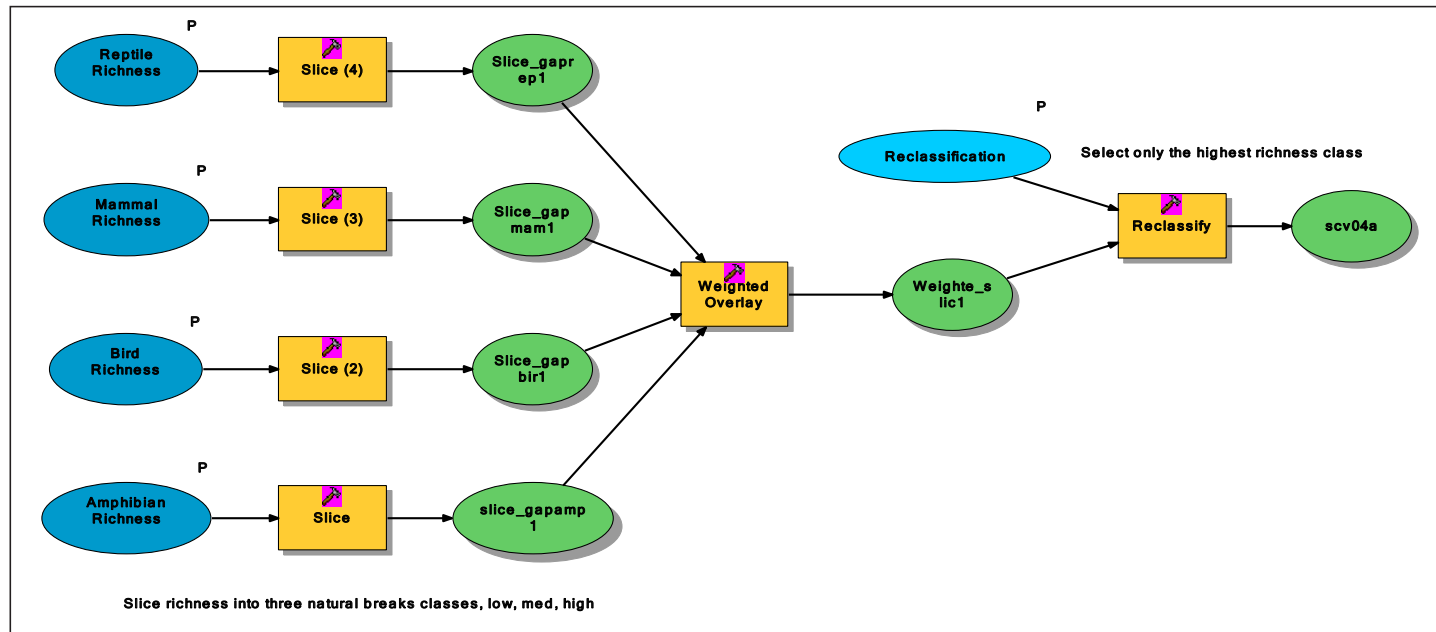

Model SCV04b: Low-Road-Density Piñon-Juniper Woodlands

This model selects Piñon-Juniper Woodlands from the New Mexico GAP Vegetation analysis, removes developed areas (e.g., high-density residential) indicated by the 2002 National Land Cover Data set, then assigns a value of 1 to all PJ Woodland. Areas with more than 1 linear mile of road per square mile block are excluded from the final output.

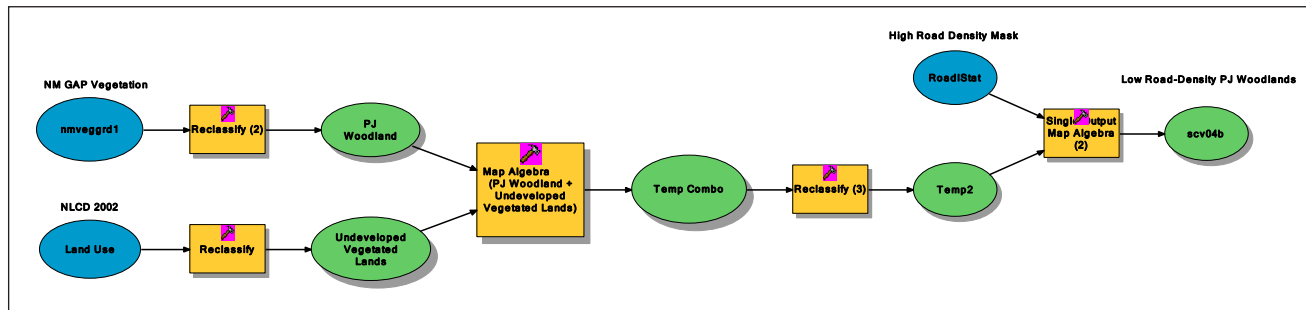

Model SCV04c: Low-Road-Density Grasslands

This model selects grasslands from the New Mexico GAP Vegetation analysis, removes developed areas (e.g., high-density residential) indicated by the 2002 National Land Cover Data set, then assigns a value of 1 to all forested lands. Areas with more than 1 linear mile of road per square mile block are excluded from the final output.

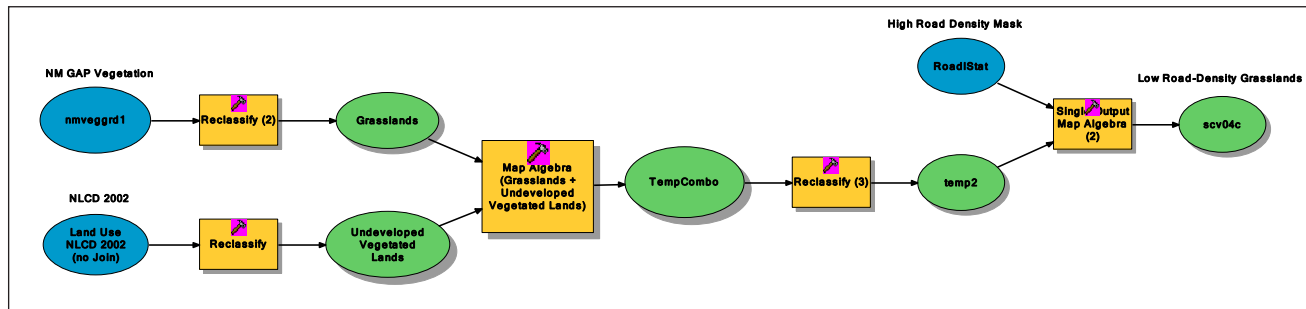

Model SCV04: Low-Road-Density Forests

This model selects forested areas from the New Mexico GAP Vegetation analysis, removes developed areas (e.g., high-density residential) indicated by the 2002 National Land Cover Data set, then assigns a value of 1 to all forested lands. Areas with more than 1 linear mile of road per square mile block are excluded from the final output.

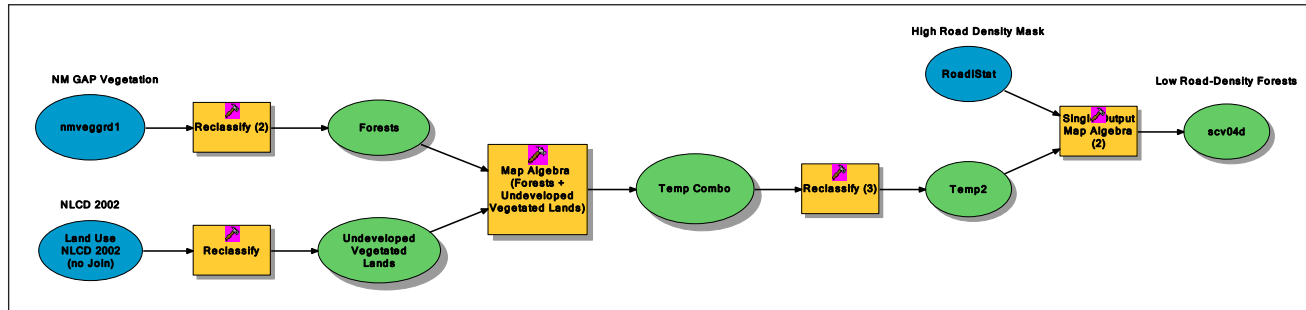

Model SCV04e: Areas Near Semi-permanent Water

This model is a composite of three secondary models in the Water Related Primary Model category SCV05a (presence of drainages), SCV05b (presence of water bodies) and SCV05d (presence of springs). These “wet” areas are assigned a value of 1 and all other areas are assigned a value of 0.

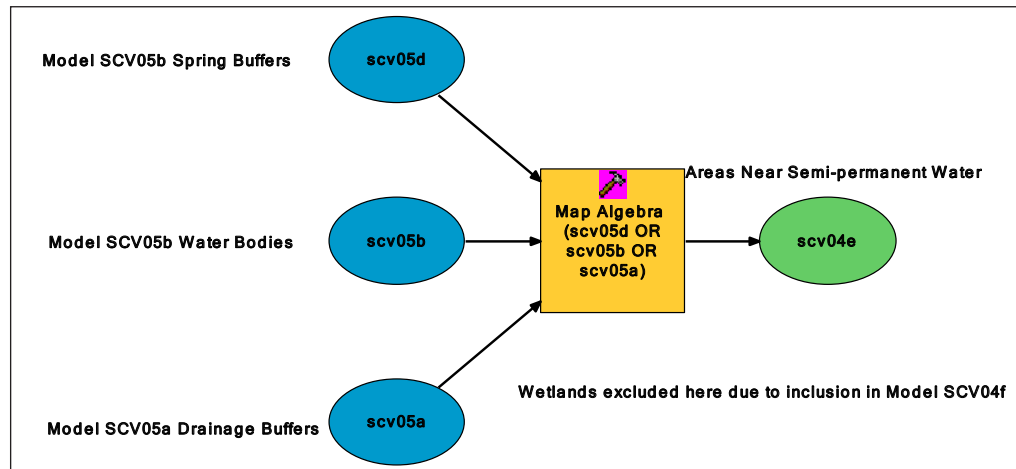

Model SCV04f: Wetland and Riparian Zones

This model is simply a copy of the output from SCV05c. See the metadata for that output layer and model.

SCV04 Composite Habitat Model

The composite Habitat Quality Model combines the component models in two ways, one based on the sum of input rasters and the other based on a weighted sum process. The unweighted sum of the five Scenic Value Component Model rasters results in a layer with values ranging from a minimum of 0 to a maximum of 5. The weighted sum process reclassifies positive output values into three classes of conservation value: moderate, high, very high. Note that for the published release of the SCV Model, all Habitat Quality Component Models were assigned equal weights in the weighted sum analysis.

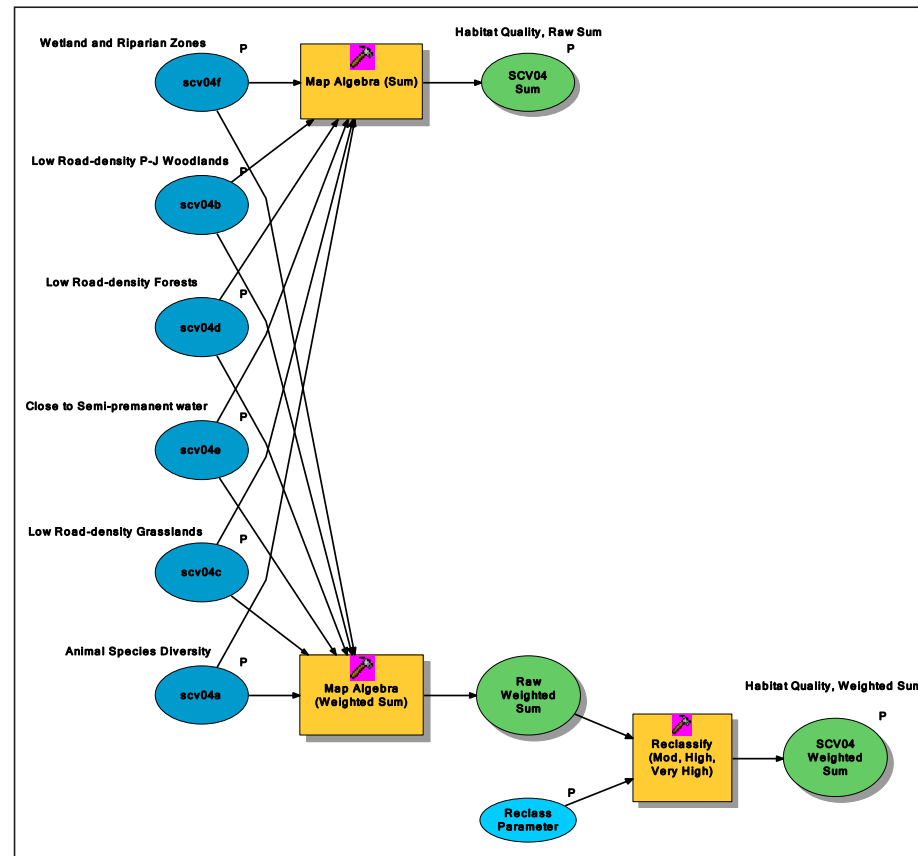

SCV05 Water Value Model

Model SCV05a: Drainage Buffers

Using the NHD vectors and their associated stream level attributes, drainages are selected and buffered in a raster environment as follows: Galisteo Creek, NE Segment (above Cañoncito), 0 to 50 m, SCV Score = 1; Galisteo Creek, Cerrillos to Cañoncito, 0 to 50 m, SCV Score = 1; First Order Tributaries to Galisteo Creek, 0 to 25 m, SCV Score = 1; Second Order Tributaries to Galisteo Creek, 0 to 20 m, SCV Score = 1; Third Order Tributaries to Galisteo Creek, 0 to 10, SCV Score = 1; Other drainages, SCV Score = 0. This model uses the 1:100,000 scale National Hydrographic Data set. The 1:24,000 scale version of the NHD was released after the model was created. Unfortunately, the stream level attribute of the higher resolution data set is not populated at this time. This attribute is necessary to automate the buffering thresholds specified by the model.

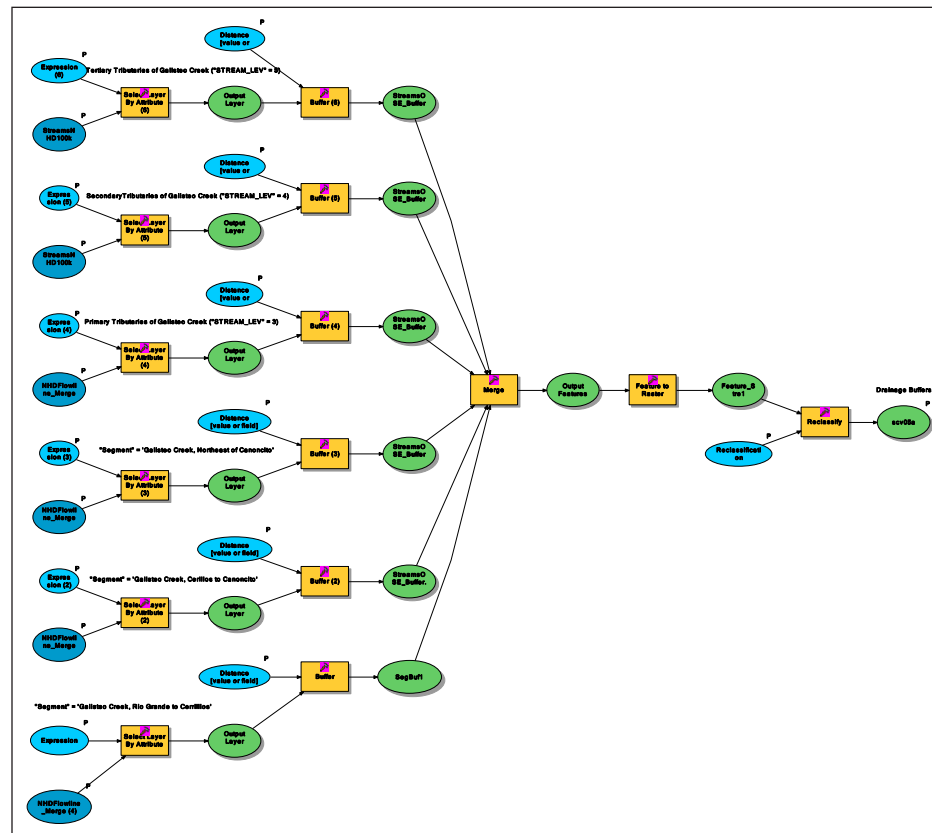

Model SCV05b: Water Bodies

This model uses data from the 1:24,000 scale National Hydrographic Data set, as well as ponds from two Earth Works Institute Projects: the 2002 EWI Ranch Riparian Vegetation Inventory and the 2006 Galisteo Wetlands Project. This model converts water bodies into raster cells with a value of 1. All other cells in the output raster get values of 0.

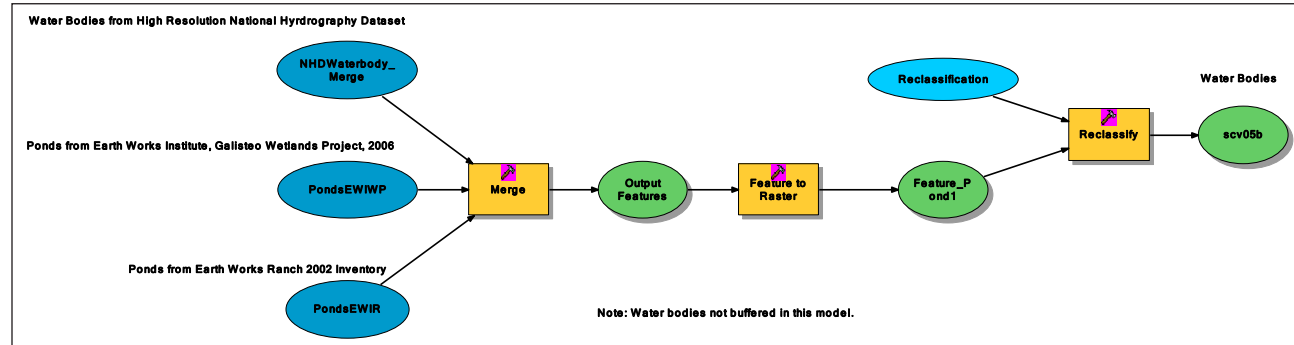

Model SCV05c: Wetland and Riparian Zones

The three input data sets are merged into a single layer, converted into a raster. Areas designated as wetlands or riparian areas are assigned a value of 1 and all other areas get values of 0. Importantly, improvements to this model might include ranking different wetland areas, QC and edit of the hand-digitized data, and use of a buffer zone around wetlands to expand the high conservation value envelope for these dynamic features. Three data sets are inputs to this model. Two of the data sets are GPS-based inventories of selected wetlands in the basin: GPS-based (GeoXT, sub-meter) data from 2005-2006 Galisteo Wetland Project and GPS-based (GeoExplorer 3; 1-3 m) data from the 2002 Earth Works Institute Ranch vegetation study. The third data set consists of probable riparian areas digitized from topos and aerial photos for an infiltration/runoff model created by EWI and Earth Analytic, Inc. in 2004-2005.

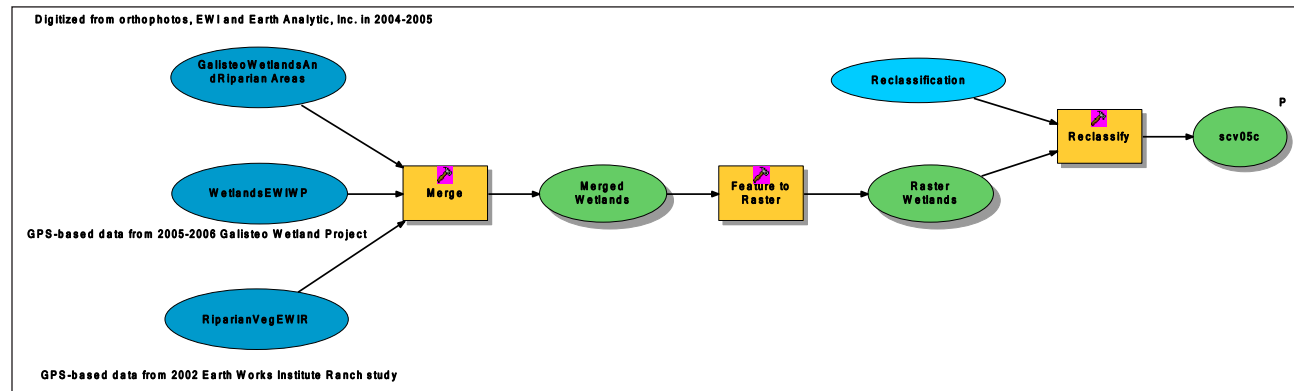

Model SCV05d: Spring Buffers

Using the nodes from the 1:24,000 NHD data set, the raster created by this model creates 35 m buffers around springs to cover potential spatial error. Cells within the buffer zone are assigned values of 1 and all other cells get values of 0.

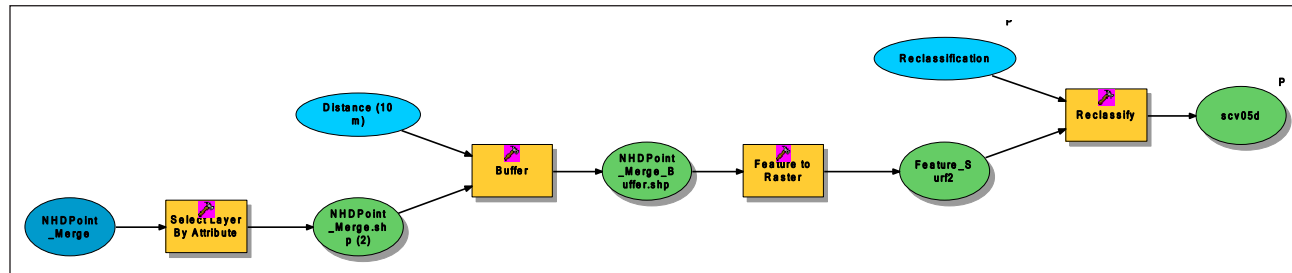

Model SCV05e: Aquifer Recharge Zones

This model rasterizes polygons representing (1) quaternary alluvium (NM Surface Geology, 1:500,000) and (2) soils (SSURGO, including prerelease data for Santa Fe County) classified as excessively or somewhat excessively drained, assigning a value of 1 to these potential surface recharge deposit areas.

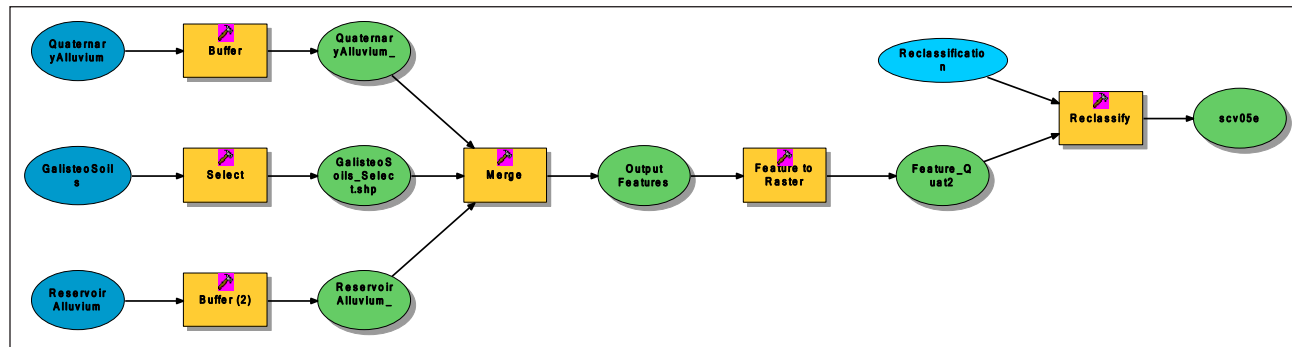

SCV05 Composite Water Value Model

The composite Water Value Model combines the component models in two ways, one based on the sum of input rasters and the other based on a weighted sum process. The unweighted sum of the five Water Value Component Model rasters results in a layer with values ranging from a minimum of 0 to a maximum of 5. The weighted sum process reclassifies positive output values into three classes of conservation value: moderate, high, very high. Note that for the published release of the GWCI Model, all Habitat Value Component Models were assigned equal weights in the weighted sum analysis.

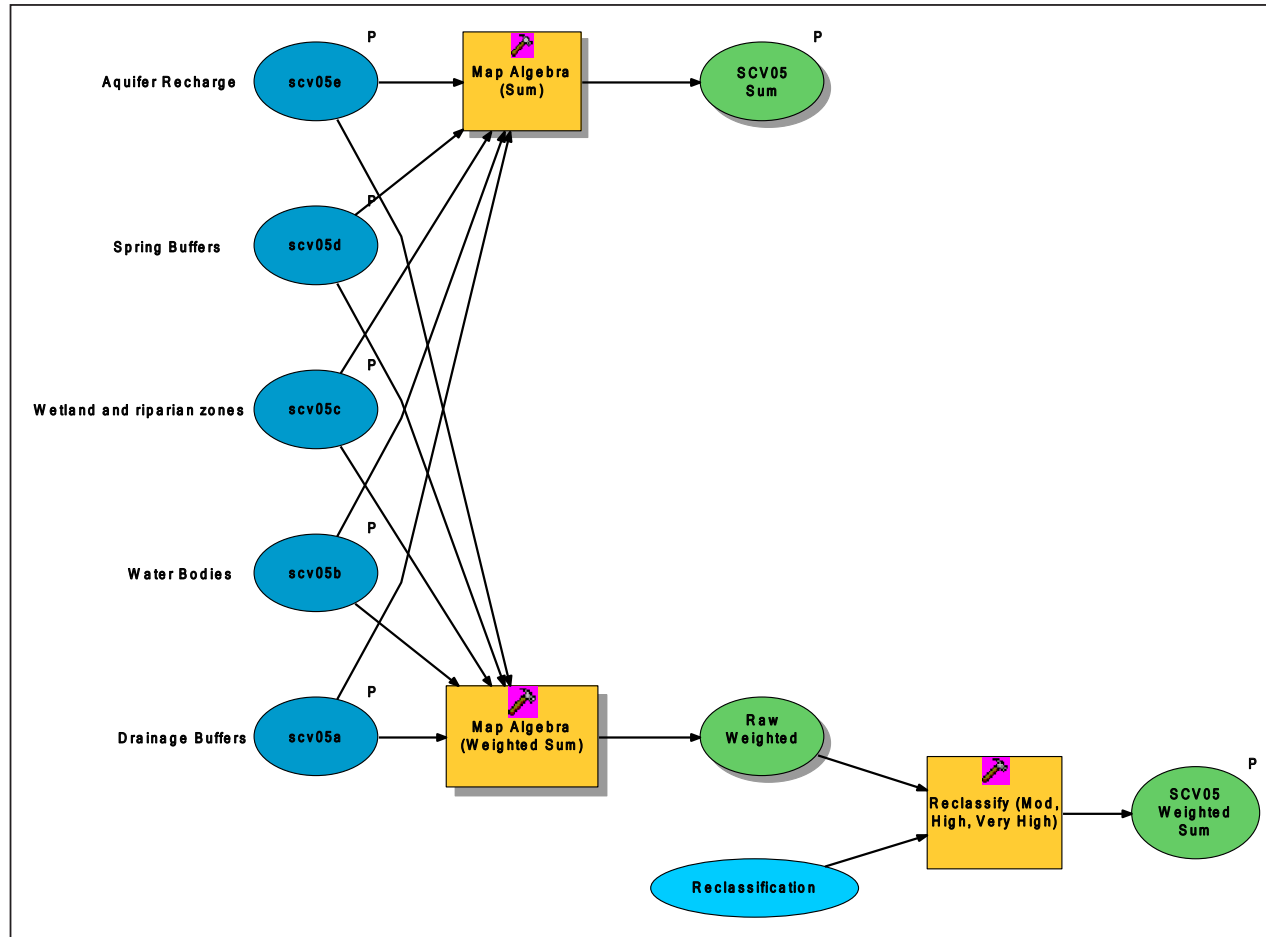

Significant Conservation Value Wrap-up Model

The Significant Conservation Value Wrap-up Model combines the component models in three ways, one based on the sum of input rasters, the second based on a weighted sum process, and the third based on the secondary weighting of the weighted sum results from the four composite models. The unweighted sum of the four primary composite model rasters results in a layer with values ranging from a minimum of 0 to a maximum of 15. The weighted sum process reclassifies positive output values into three classes of conservation value: moderate, high, very high. Note that for the published release of the GWCI Model, all of the primary composite models were assigned equal weights in both the weighted sum and double-weighted sum outputs from the Conservation Wrap-up Model.

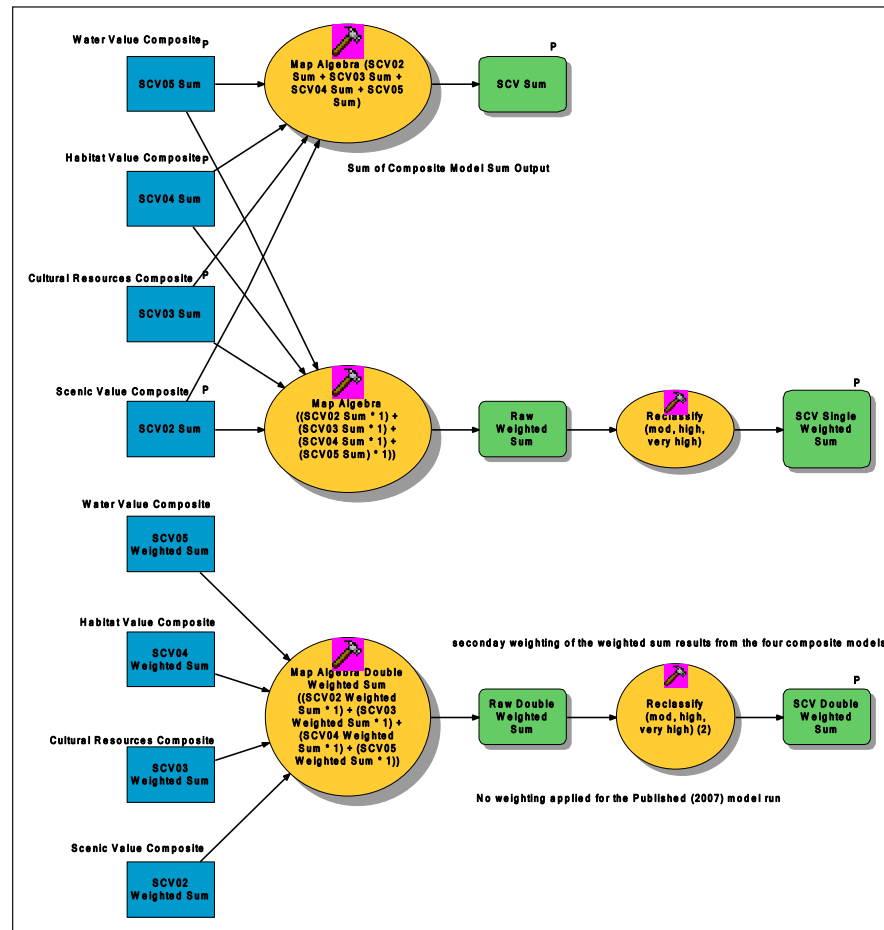

Post-Model-Run Analysis Models

Several additional models were developed to facilitate quantitative assessment of conservation values for specific parcels.

Target Easement Model

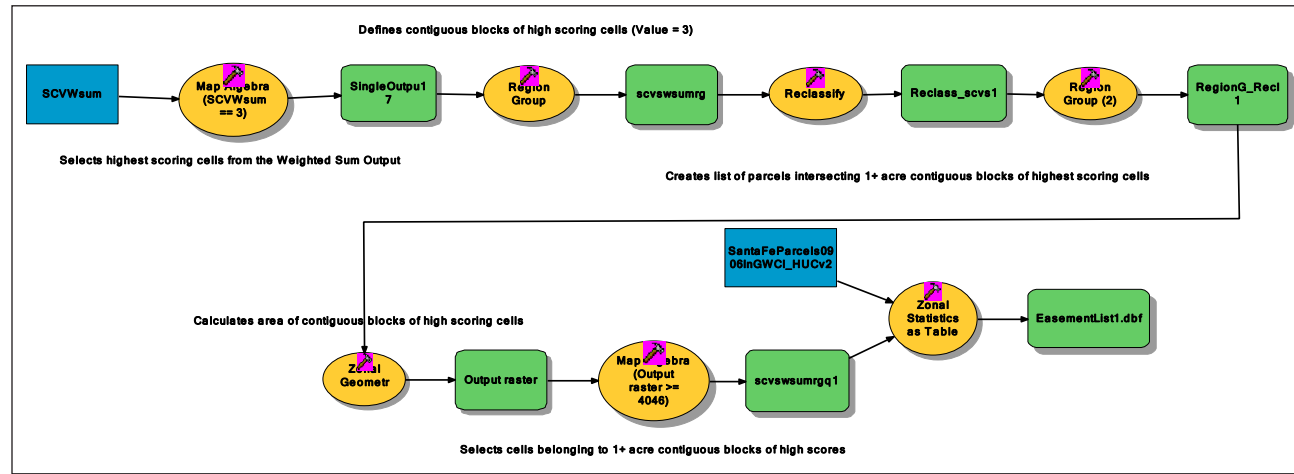

This model uses the weighted sum output from the Significant Conservation Value Wrap-Up Model as the basis for identifying parcels intersected by contiguous one-acre-plus zones of maximum conservation value (Very High, 3). More specifically, the model selects cells classified as “Very High” from the weighted sum output from the Wrap-Up model, defines contiguous blocks of these cells, and then further subdivides the output into contiguous blocks of high-scoring cells using the region group and zonal geometry functions. Finally, the model runs zonal statistics on the intermediate output with the parcel data set, identifying parcels that intersect these contiguous blocks of high-scoring cells. An example of the Target Easement Model results is shown in Figure E-1.

Figure E-1. Target Easement Model

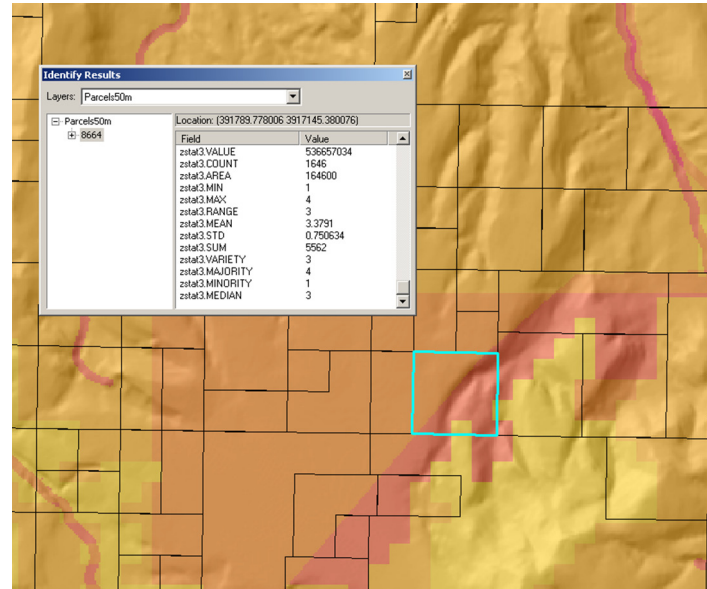

Parcel Zonal Statistics

This analysis model calculates zonal statistics for each output from each Composite and Wrap-up Model, using the Santa Fe County Parcel layer (09/2006) as the zone data set. To capture a summary of statistics for each parcel, the unique ID field called PRCSFCO_ was used in the zonal statistics tool. A separate table is generated for each model output. The statistics summarize model scores for each parcel based on the number of cells of each unique value that fall within a given parcel.

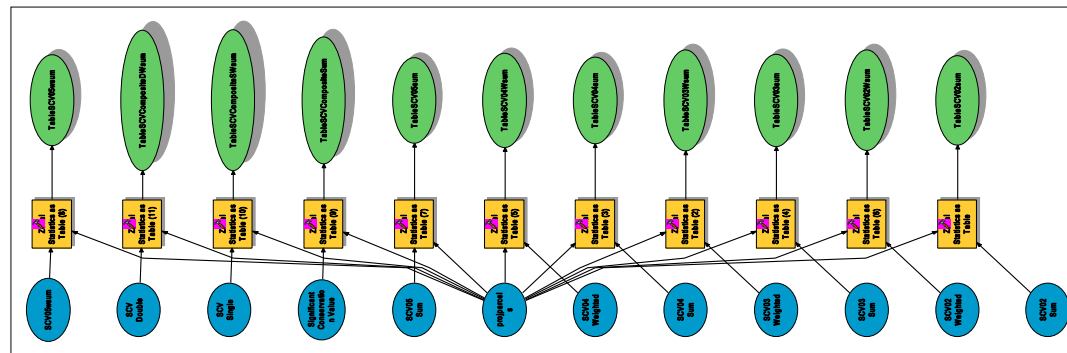

Once the calculation of zonal statistics has been completed, these values can be joined to the digitized site polygons, facilitating the assessment of variability in conservation value across parcels.

Zonal statistics link example:

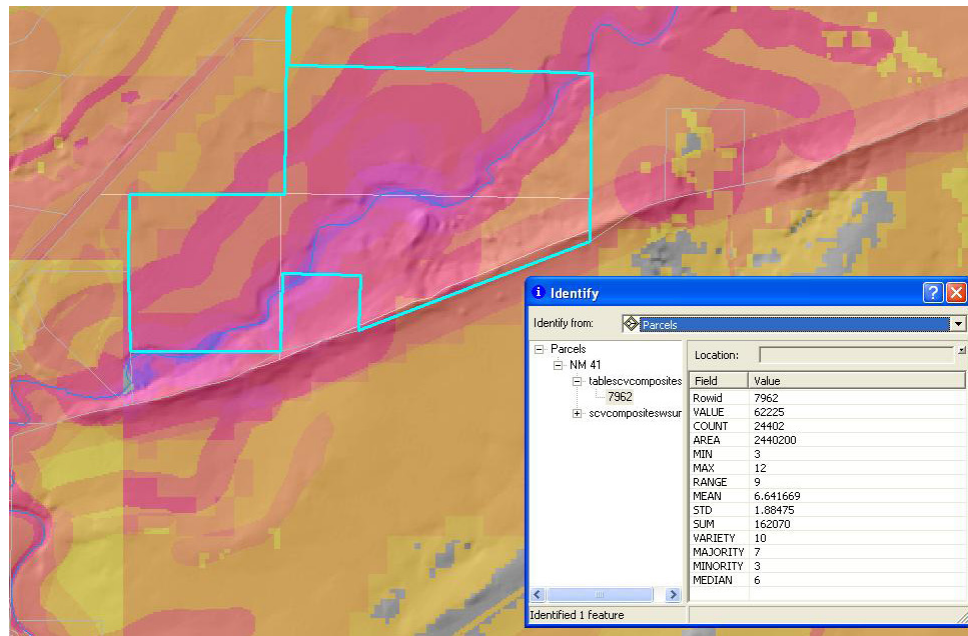

The GWCI framework is designed to allow easy calculations of summary statistics for parcels (or any polygons, for that matter). The following are some examples of the kinds of queries one might run on the model result parcel statistics.

QUERY: 50,000 private acres in the watershed with highest average composite

SOLUTION: To calculate this, one would run the ZS function using the parcels designated as privately owned as the input “zones” and the GWCI overall composite conservation priority surface as the value layer to be summarized. This function would return a suite of statistics summarizing the cell values that fall within each selected polygon. Each privately owned parcel would have a mean score (as well as max, min, majority median, std, etc.) that could be used in concert with the area (acreage) of that parcel to come up with the 50k private acres with the highest mean score. Importantly, however, one might want to look at other statistics (e.g., majority) or take into account spatial contiguity of high scores. An example of the former would be the identification of all private parcels that have a majority score (the majority of cells in the parcel) of at least 5 or 6 (or whatever the high end of the composite score potential is). To get at contiguity, we could reclassify the

composite conservation priority surface so that contiguous areas of cells with scores of x or more (e.g., 6) are assigned a unique code indicating they meet that criteria. Then, parcels that overlie these contiguous blocks of high scores could be identified. In some cases, it would make more sense to look at acquiring easements in portions of parcels overlying these high-score blocks, rather than acquiring/conserving entire parcels.

QUERY: total average composite scores of all parcels greater than 1000 acres in size

SOLUTION: Select all parcels greater than 1000 acres in size, and then run zonal stats with the composite conservation priority surface as the value raster. This yields average scores for each parcel.

QUERY: high significant values (in all 6 categories) of all parcels greater than 1000 acres in size

SOLUTION: For each Primary model category (e.g., cultural resources), the output conservation value scores range from 0 to 3, where 1 is moderate SCV and 3 is high SCV. These ordinal rankings are generated in each of the Primary model wrap-ups (composite models for each category), taking the full range of scores generated through the straight (or weighted) sum of overlapping scores and slicing that variability into three classes. That said, one could run ZS on parcels greater than 1000 acres for each Primary composite model. Using the resulting scores, one could then select all parcels that scored medium and/or high for all 6 models. This would provide the solution required by the query.

QUERY: composite map - gross illustration of internal areas of higher significance

SOLUTION: Use the Primary composite model surfaces and the overall composite model surface as background images with parcels, roads, and other contextual information overlaid on them. The model surfaces can be symbolized to show relative score values, from low to high, with color ramps ranging from light to dark or one color to another (e.g., yellow to red).

QUERY: map of all high significant values (all six categories) - more detail on internal variability

SOLUTION: See above

APPENDIX F: EXPERT INPUT PROCESS

Methodology and Purpose

Under Task 3 of the Galisteo Watershed Conservation Initiative’s methodology — “Developing a Prioritization of Open Space Options and Acquisitions” — the project team conducted an expert review process. The process included meetings with professionals as well as public meetings hosted by the Galisteo Watershed Partnership to get feedback on the preliminary map output of Task 2: “Developing GIS Maps for Analysis.”

The expert review process assisted the team with data refinement and with prioritizing open space conservation options. The objective of the expert review was to refine the SCV (Significant Conservation Value) data sets by including additional spatial information on conservation values in the watershed and modifying weighting values to arrive at conservation priorities that were based on the best knowledge available in the region. This qualitative analysis was added to the project methodology to correct any errors and omissions resulting from the more linear and quantitative GIS modeling methodology.

Expert Review by Professionals

The project team invited professionals from various disciplines to participate in group meetings to review map outputs. Groups were formed for four land value attributes:

- Cultural resources
- Natural (Biotic) resources
- Scenic resources
- Water resources

The expert review groups were presented with specific questions to gather their collective wisdom about the land attribute maps under their review. The groups considered issues such as:

- Data gaps
- Inconsistencies or data output problems in the GIS and mapping methodology
- The need to identify buffers and connective corridors between SCV areas
- Additional roadless, landlocked areas that are prime conservation targets

- Areas expected to be affected by development, recreation, infrastructure projects, etc.
- Areas of high conservation value based on specific features, history, spiritual value, cumulative landscape-wide effects of the ecosystem, and other factors that were not covered by the GIS system
- Changes in the weighting of identified SCV areas

Findings of the Expert Review Groups

Cultural Resource Areas Group

The Cultural Resource Areas group met on April 18, 2006. The group consisted of:

- Bill Baxter (Cerrillos Hills Park Coalition)
- Fred Friedman (New Mexico Railroad Commission; retired)
- Charles Haecker (National Park Service Historical Archeologist)
- Homer Milford (New Mexico Abandoned Mine Lands; retired)
- Cordelia Snow (New Mexico Historic Preservation Division)
- Dorothy Victor (New Mexico Historic Preservation Division)
- Mac Watson (Cornerstones)

The group recommended that all registered state and national cultural resources and the additional significant resources listed below be added to the system as SCV03d and given the same weight as the other categories.

1. Railroads: Santa Fe Southern, Burlington Northern, and New Mexico Central lines, plus abandoned short lines if they can be located.
2. The sandstone quarry on Cerro Colorado above Lamy.
3. Camp Manzanar and Bishop Lamy's Retreat remnants on the railroad line at the mouth of Apache Canyon.
4. Lamy Depot and church buildings (the Lamy store/saloon, which is listed on the state and national register, does not show up on the current data layer, and should be added).
5. Historic Roads: Old Santa Fe Trail (NPS NHT map), Route 66 (see State Register listing #1564), Camino Real below La Bajada, and prehistoric Pecos trail just north of El Dorado.

6. Ortiz Mine (non-historic) and Real de Dolores remnants as a significant area for restoration and preservation.
7. If not already listed in ARMs, the following should be added:
 - Carbonateville town site
 - Rogers town site
 - Bishop Lamy's lime kiln (north of Lamy)
8. Glorieta Baldy Fire lookout, which is listed in the State Register.
9. Consider adding undermined areas in and around Madrid. National Historic Landmarks (San Lazaro Pueblo and Glorieta Pass Battlefield) should be bumped into the "super-significant" rating.

Natural (Biotic) Resources Group

Two separate meetings were held for this group Forests, Woodlands and Range on May 3, 2006, and Wildlife Habitat on May 4, 2006.

The group on May 3 consisted of:

- Bryan Bird (Forest Guardians)
- Ann Watson (Santo Domingo Pueblo)
- Thor Sigstedt (Adventure Trails Ranch)
- Jan-Willem Jansens (Earth Works Institute)
- Wetherbee Dorshow (Earth Analytic)

The group on May 4 consisted of:

- Robert Findling (The Nature Conservancy)
- Dave Johnson (City of Santa Fe)
- Nicole Rosmarino (Forest Guardians)
- Thor Sigstedt (Adventure Trails Ranch)
- Alan Ragins (National Park Service)
- Jan-Willem Jansens (Earth Works Institute)

The group concluded that the following data sets need to be added:

- a. Terrestrial ecosystem surveys from the U.S. Forest Service. To be downloaded from the FS Region-3 website.
- b. A map of private forest lands and their fire history from the State Forestry Division.
- c. GIS viewshed analysis tools from the Forest Service.
- d. Potential water holding areas/soils (environmental consultant David Groeneveld will be contacted to provide data from wet and dry years and the subtraction data that show where there might be potential water holding areas/soils).
- e. Find the real SCV areas (from a habitat point of view) and value (some areas deserve higher weights) and buffer them by combining maps for:
 - i. Connectivity and fragmentation (select large contiguous landholdings)
 - ii. Roadless areas
 - iii. Riparian zones
 - iv. Culverts that show connections between areas
 - v. Specific species habitat (higher priority vegetation types).

Throw out the values that are based on the NDVI data (perhaps by first identifying to what extent invasive species data overlap with NDVI data for grasslands and perhaps forests).

Look for areas with less than 1 mile of road per square mile of forest, woodland, or range. This is an acceptably low figure for wildlife habitat values (we should look into the FS standards to verify these standards).

- f. Map where certain natural dynamic processes can still happen: fire, flooding, animal movement (e.g., the analysis points “d” and “e” above; soil and slope characteristics relevant for prairie dog habitat; riparian areas; private forests/woodlands/rangelands that link public forests/woodlands/rangelands, and that link the forests to floodplains).

- g. Map habitat for keystone species in the area (e.g., prairie dog, pronghorn, cougar, bear, beaver, mule deer, piñon jay, New Mexico milk snake). Get pronghorn information from New Mexico Game & Fish, which describes minimum habitat size (polygon size), connectivity needs, and buffer needs. Get more information from the big ranches (wildlife studies and information about hunting).
- h. List aquatic indicator species and identify the areas where these species occur.
- i. Obtain BLM maps for ACEC (Areas of Critical Environmental Concern) for the Galisteo Watershed.
- j. Use information from Robert Findling about Ortiz Mountain Ranch. Add this information to the map on existing conservation/open space areas in the watershed. The TNC area precludes road and trail development.
- k. Study aerial photographs (or have them taken) to study prairie dog habitat in the watershed (with student help from CSF), and solicit assistance from the Heritage Program (Chris Johnson).
- l. Do a separate grassland study.
- m. Include data from the Cerro Pelon wildlife study:
 - The current habitat at Cerro Pelon Ranch is not suitable for Rocky Mountain bighorn sheep (*Ovis canadensis*) due to high mountain lion predation risk (high occurrence of piñon-juniper brush and rough topography) and potential risk of *Pasteurella pneumonia* contamination from domestic sheep. These conditions occur in most if not all of the Galisteo Basin, which by extension makes the watershed unsuitable for Rocky Mountain bighorn sheep.
 - Shortgrass grassland habitat is the favored habitat type for pronghorn (*Antilocapra americana*). Pronghorn need a water source at a distance of about four miles and grassland with forbs in the vegetation mix. In addition, fences need to be constructed to allow pronghorn to crawl under them (a space of 14 inches or higher is required). There is potential and existing pronghorn habitat on nearly all grasslands in the watershed (if not overgrazed by cattle), provided there are water sources on these grasslands. Fragmentation is the greatest obstacle to pronghorn migration to suitable habitat throughout the watershed (notably highways and highway fences, large volcanic dikes, and contiguous ridges with piñon-juniper vegetation). Distance to development may also play a role.
 - Large parts of Cerro Pelon Ranch are mule deer (*Odocoileus hemionus*) habitat, particularly arid open areas and hillsides and piñon-juniper woodlands. Mule deer need spring/summer forage of grass and forbs and fall/winter forage of browse (shrubs). Mountain lions are the main mule deer predator in the watershed (in addition to

humans). Most of the Galisteo Basin comprises existing and potential mule deer habitat, except dense forest and piñon-juniper areas, large open grasslands, and inhabited areas.

- Mountain lions also live on Cerro Pelon Ranch, which provides a habitat consisting of canyons and cliffs, dense woodlands, and arroyos. Mountain lions prey on all the species mentioned above (and domestic animals as well). Mountain lions live throughout the watershed in the habitat types described, and are at the top of the food chain of many species in the watershed.

The group felt that the proposed weighting of values does not need to be changed to better guide conservation priorities. The group did not identify any additional areas (buffers or corridors) adjacent to the identified SCV areas that should be noted as priorities for conservation; no additional corridors are needed.

Scenic Resources Areas Group

The group met on June 15, 2006. The group consisted of:

- Lucy Lippard (longtime Galisteo resident, Basin hiker, author)
- Bill Baxter (longtime Cerrillos resident, local historian, author, Basin hiker)
- Tami Torres (Bureau of Land Management scenic resource specialist, Taos Field Office)
- Ted Harrison (Commonweal Conservancy/Galisteo Basin Preserve)
- Stu Patterson (amateur archeologist, Eldorado resident, Basin hiker)
- Jan-Willem Jansens (Earth Works Institute, facilitator/presenter)
- Rici Peterson (Santa Fe Conservation Trust, facilitator/recorder)

The group recommended that the following areas with intrinsic, significant conservation value (SCV) are missing and should be added to the GIS data sets:

Sites worth preserving:

- “The Hub” (on San Cristobal; parallels Highways 285 and 41)
- Pueblo Blanco
- La Jolla, also known as the Llano (southwest of Cerro Pelon, borders on Lone Mountain Ranch; has petroglyphs, Hispanic ruins, red cliff formations called Chorro Cliff; see Lucy Lippard for more specific location information)

- San Lazaro
- Devil's Throne (immediately west of Cerrillos village; provided stone for the Santa Fe Courthouse)
- Cerro Colorado, also known as Cathedral Hill (Source of stone for St. Francis Basilica, formerly known as St. Francis Cathedral)
- Any riparian areas within the Basin (entire Galisteo Creek corridor)
- Final Galisteo Grant (360 acres on Cerro Pelon Ranch)
- Cadial Grant (On strip paralleling San Cristobal/Galisteo fenceline)
- Petroglyph Hill
- Lower the weight of La Bolsa (located two miles south of Madrid)
- Village of Galisteo
- Village of Madrid
- Village of Cerrillos
- Railroad Main Line experience (Cultural as well as scenic value)
- Grade for old Chili Line
- La Bajada (The most dramatic parts are not within the Galisteo Basin, but can be seen from I-25, which is inside the project area; "Number of person-experiences" points: La Bajada is an area where many people can experience open space; or the Hwy 14 grasslands looking south)
- Other places outside Galisteo Basin boundaries but within its "area of influence" (Mt. Taylor, Sandia Mountains, Manzano Mountains, Sangre de Cristo Mountains, Jemez Mountains)
- Pronghorn and pronghorn viewing areas
- Highway corridors themselves (Highway 14, County Road 42, Highway 41)
- Clark Hill near Zorro Ranch
- Area around old bridge across Highway 41 in Galisteo village (Few know about it but it is a well-used gathering place for locals)

- “Points of Entry” for travelers
 - “Lamy Hill” (Highway 285 near railroad tracks)
 - “Entry experience” for southbound travelers
 - Breathtaking and sudden change of scenery; Basin is revealed
 - Edge of Estancia Basin
 - Northbound on 41
 - Northbound on 285 from Clines Corners
 - La Bajada
 - Waldo Canyon Road (CR 57)
 - Highway 14 northbound south of Madrid
 - Highway 14 along Rancho Viejo and State Trust lands
- Southern end of County Road 51
- Rowe Mesa (Local topography; rich wildlife viewing opportunities)
- Gold Mine Road looking north
- Hacienda Doña Andrea
- Galisteo Creek Headwaters forests
- Eldorado Wilderness (Including escarpment beyond east side of Galisteo Creek)

Pullouts and vista points:

- Public trail on Galisteo Basin Preserve
- Plaza at Galisteo Basin Preserve (will frame a view of the Basin)
- I-25 rest area overlooking Santa Fe (technically outside the watershed)
- Pullout creation will happen naturally as part of NMDOT and county road-building
- Some objections to “fascist pullouts” (restricting free choice when vista points are chosen by government entities)

- Pullouts are constituency-building opportunities
- Interpretive resources for pullouts (XM radio stations; audio tours (CD or MP3); brochures; wayside panels)

Other Scenic Resource information sources:

- Santa Fe County has developed a Visual Resource Inventory circa 1995
- BLM rating system
 - Inventory objectives
 - Compare to other values

The group felt that the proposed weighting of values did not need to be changed to better guide conservation priorities. The group felt that no additional areas (buffers or corridors) adjacent to the identified SCV areas were necessary.

The group made the following recommendations to improve the usefulness or veracity of the model:

- Make maps consistent by showing government-owned properties.
- Take a multi-pronged approach by using multiple scales for values.
- Carefully consider the number of viewer experiences as a factor when weighting values:
 - Don't overvalue or undervalue
 - Weighting should be left up to users of the model (scenic values are in the eye of the beholder)
 - "Sense of place" factors are most important in valuing scenic areas: "what do you hate to miss about the watershed?"
 - We also need to be practical, picking our fights based on the feasibility of open space preservation (e.g., Rancho Viejo open space may be low hanging fruit); we need to see what strategies are most practical: highest SCV, community separation or entry character.

Factors to consider:

- The Railrunner route alignment decision may affect planning
 - Route itself may become a scenic resource experience
- Create an agreement with Rancho Viejo and State Land office to protect 12,000 acres

Suggestions for application of model:

- “Community separators”
 - Keeping communities separate as growth fills in space between villages (the European model) will preserve individual village character
 - Consider adding “community separator” as a value in the model
- Avoid “Tragedy of the Commons”
 - Boulder, Colorado greenbelts are heavily overused
 - Near-solid development from Colorado Springs to Fort Collins

Suggestions for report:

- Describe the different scales of protection that are in place (State vs. BLM land vs. conservation easements, vs. open ranch land vs. County Open Space, vs. a traditional community like Galisteo; vs. a stream corridor protected by FEMA map designation and common sense)

Water, Wetlands & Riparian Areas Group

This group met on two dates: April 19, 2006 and May 16, 2006.

The group on April 19 consisted of:

- Steve Vrooman (Keystone Restoration Ecology)
- Andrew Jandacek (Santa Fe County - Planning Division)
- Maryann McGraw (New Mexico Environment Department, Surface Water Quality Bureau, Wetland Program)
- Jan-Willem Jansens (Earth Works Institute)

The group on May 16 consisted of:

- Steve Vrooman (Keystone Restoration Ecology)
- Maryann McGraw (New Mexico Environment Department, Surface Water Quality Bureau, Wetlands Program)
- Jan-Willem Jansens (Earth Works Institute)
- Sigmund Silber (Galisteo Basin Resident; Board member of the San Marcos Association)

The group recommended that the following areas with intrinsic, significant conservation values (SCV) be added to the GIS data sets:

- Springs (see topo map quads for the watershed).
- Duke Engineering and Services (2000):GIS shape file of spring locations; White and Kues (1992): – Inventory of springs in New Mexico; Shomaker et al. (2001):Tabulated spring data for the Eldorado area U.S. Geographic Names Information System (<http://nhd.usgs.gov/gnis.html>); Point data for spring locations from USGS 7.5-minute topographic quadrangles; Blake et al. (1995): Tabulated spring data for the Los Alamos area; Purtyman et al. (1980): Tabulated spring data for the Los Alamos area; Purtyman et al. (1993): Tabulated spring data for the Los Alamos area; U.S. Army Corps of Engineers (2000): Upper Rio Grande Water Operations Model (URGWOM) data. These data were combined and compiled into a single GIS shapefile that is geographically referenced and can be combined as an overlay with the model grid. These data identify and locate known springs in the study area from the available literature. Additional data may also be evaluated for public water-supply systems that draw water from springs. These data will be obtained from public water-system data sources such as the New Mexico Drinking Water Bureau and the WATERS database.
- USGS conducted a geomorphological study in the Galisteo watershed in 2002-03 (John Rogers). These data sets may be important to locate additional alluvial fans, springs, and historical wetlands.

The group recommended the following changes to the proposed weighting of values to better guide conservation priorities:

- All headwaters of the Galisteo Creek are of greater importance for conservation than currently indicated due to their impact on the downstream watershed (water quality and quantity). Therefore, all creeks that are tributaries in the forested upper watershed (north of I-25) need to be upgraded one class of importance. The Galisteo Creek in the Glorieta-Valencia-Cañoncito corridor needs to be upgraded one step also. (Deer Creek, Grasshopper Canyon, and other small tributaries need to be upgraded to yellow; Apache Canyon should be upgraded to orange).

- For alluvial areas and river bottoms: All rivers and streams should receive an elevated value (e.g., orange) for the belt-width of the floodplain (the belt or zone within which the channel meanders).

The group recommended that the following buffers adjacent to the identified SCV areas should be noted as priorities for conservation. The group felt that no additional corridors were needed.

In terms of terrain management, development (homes, trails, etc.) should be allowed in any buffer zone only to the extent that all impacts from the development or land use are 100% mitigated (0-impact).

- a. For all public and private forest lands in headwaters: These areas should be made a buffer zone for water courses and wetlands (to protect the water courses from poor grazing, offroad vehicle impacts, logging/thinning impacts, fire, heavy recreation impacts, mining, etc.).
- b. For all springs, wetlands, and riparian areas: These areas need to be buffered. The buffer zone should cover the entire drainage area upstream from springs and/or wetlands, and should include any valley sides draining into the spring or wetland. Regarding trails, this may require special designs (e.g., boardwalks). Specific attention should be paid in the buffer zones not to reduce natural infiltration levels and not to increase natural erosion and sedimentation levels.
- c. For alluvial areas and river bottoms: Alluvial areas need to be given a buffer zone only if the river and floodplain hug the sides of the alluvial area. The buffer zone width should be the same as the floodprone width of the river or arroyo and should be applied on both sides of the stream.
- d. For all steep slopes and escarpments: Slopes and escarpments with slopes of 40% or greater must be made buffers to protect downstream water courses.
- e. For all areas with headcuts: Use Spatial Analyst to find areas with an extensive pattern of headcuts. All areas with headcuts need to be buffered upstream from the headcuts. The buffer extends from the headcuts to the change in soil type and/or slope immediately upstream/uphill and on the side of the valley. This is important to prevent the development of badlands and areas that cause severe erosion and rapid drainage of historical alluvial soils/valley bottoms.
- f. Large arroyos: All large arroyos (either due to a drainage area of more than 640 acres or due to being a first- or second-order tributary to the Galisteo Creek) should have the same buffering protocol as streams: buffer width is floodprone width at both sides of the arroyo's upper edges.

- g. Small arroyos: All other arroyos should have a buffer following the County Land Use Code (for Terrain Management): buffer width is 50 feet on both sides of the arroyo.
- h. Buffer zones: Buffer zone dimensions should be variable and specific to local and surrounding ecological conditions that require protection and the impacts from outside the buffer zone from which protection is being sought.

Public Outreach Meetings

Toward the end of the GWCI process, in 2007 and 2008, public comments were gathered on preliminary map outputs and on specific issues that represented land attributes for the SCV method. Public comments were gathered in the context of the Quarterly Forum Meetings of the Galisteo Watershed Partnership.

The public meetings confirmed the project team's findings and repeated to some extent the feedback from the various expert groups. Public forums on wildlife conservation in early 2008 revealed a great interest in wildlife conservation and the importance of the Galisteo Basin for wildlife habitat and linkage opportunities between different ecoregions. The public forums on wildlife also underscored the vast lack of data on wildlife in the Galisteo Basin.

APPENDIX G: LIST OF CONSERVATION ORGANIZATIONS

COMMONWEAL CONSERVANCY: www.commonwealconservancy.org

EARTH WORKS INSTITUTE: www.earthworksinstitute.org

LAND TRUST ALLIANCE: www.lta.org

NATURAL RESOURCES CONSERVATION SERVICE NM: www.nm.nrcs.usda.gov

THE NATURE CONSERVANCY: <http://www.nature.org/aboutus/visionmission/index.htm>

NEW MEXICO LAND CONSERVANCY: www.nmlandconservancy.org

SANTA FE CONSERVATION TRUST: www.sfct.org

TAOS LAND TRUST: taoslandtrust.org

THE TRUST FOR PUBLIC LAND: www.tpl.org

U.S. FISH & WILDLIFE SERVICE GRANTS PROGRAMS: <http://www.fws.gov/endangered/grants/grant-programs.html>

APPENDIX H: ABOUT SANTA FE CONSERVATION TRUST AND EARTH WORKS INSTITUTE

Santa Fe Conservation Trust

The Santa Fe Conservation Trust is dedicated to preserving northern New Mexico's open, natural lands and waters, developing trails, and conserving the farms, ranches, and traditional landscapes of our diverse culture. Our goal is to protect natural lands that preserve quality of life in our region.

Our work is based on partnerships with willing landowners and participants who share an understanding of the important role healthy natural lands play in our world. Specific services include working with landowners, community groups, and government partners to develop voluntary land protection agreements (conservation easements) that retire development rights, enhance the land and memorialize landowner's wishes for all time. The Galisteo watershed has been identified as an area rich in natural and cultural resources and as such is a high priority area for the Trust. As of 2011, the Santa Fe Conservation Trust has protected more than 33,000 acres of private and public lands in Santa Fe, San Miguel, Rio Arriba, and Taos counties.

We also work with communities to create, connect, and care for local and regional trails for public enjoyment. We coordinate trail users and stakeholders to work toward a vision of well-planned, well cared-for trail systems connecting neighborhoods, communities, and regions.

We also co-sponsor the all-volunteer Trails Alliance of Santa Fe, which helps improve and maintain area trails.

Other expertise offered by the Santa Fe Conservation Trust includes:

- Professional advice for landowners and resource managers on a full range of land conservation issues
- Continuing education for professionals on land conservation-related tax, estate planning, and real estate issues.

Earth Works Institute

Based in Santa Fe, New Mexico, Earth Works Institute has worked since its incorporation as a 501(c)(3) nonprofit entity in 1994 to help communities build capacity to restore, protect, and live in harmony with their natural environment. Our educators, career trainers, planners, and ecologists help communities transition toward economic resilience by improving environmental health and identifying the economic benefits of nature. We call such resilient and environmentally responsible communities EcoWise Communities. From the ground up, EWI pursues its EcoWise Communities campaign by mobilizing communities, empowering youth, and facing climate change.

- We organize and educate community-driven land stewardship coalitions of schools, farmers, ranchers, and land conservation groups in rural, sub-urban and urban communities.
- We promote bio-technical land stewardship solutions working with private landowners, public land management agencies, and tribes.
- We connect people to the land through outdoor education and discovery, green careers training, promotion of local food production, and land restoration activities.
- We employ a young adult climate corps to reduce our carbon footprint, equip young adults for careers, and mobilize communities to act in response to climate change.

APPENDIX I: GALISTEO SPECIES—BIOTA INFORMATION SYSTEM

Species	Legal Status ^a	GAP Vegetation ^b	Beneficial Management ^c	Adverse Management ^d
Bald Eagle	<i>ST, SGCN</i>	SGS, LR, PJ-PS	Wetlands, regulate take, allow movement to available habitat, restrict disturbance of species and habitat, habitat with large trees, snags (large trees remaining to die in place), old growth vegetation	Human disturbance to nests and winter roosts, loss/degradation of breeding & wintering habitat, incl. declines in prey populations & in nest/roost site availability, environmental contamination, electrocution, illegal killing by shooting & poisoning
Northern Goshawk	<i>SOC, Sen, SGCN</i>	LR, PJ-PS, PP	Forests with uneven ages, timber stand management, mistletoe; regulate take; habitat with large trees, wilderness, woodlots; vegetation with old growth forests, ecotones	Loss or alteration of forest habitat from timber harvest, fire, disturbance to nesting birds, illegal shooting and taking
Peregrine Falcon	<i>SOC, ST, SGCN</i>	SGS, LR, PJ-PS, PP	Restrict disturbance of habitat	Chemical contamination of environment, disturbance of nesting pairs, illegal taking
Mountain Plover	<i>SOC, Sen, SGCN</i>	SGS	Large habitat patch size, heavy (vs. none) and controlled (vs. uncontrolled) livestock grazing, dirt and other open stock tanks, regulate take, restrict disturbance of species and habitat	Loss/alteration of prairie breeding areas from agricultural conversion, energy development, surface mining, exotic vegetation, loss of native grazers incl. prairie dogs, loss/fragmentation of migration & wintering areas from conversion, urbanization, environmental contamination
Yellow-billed Cuckoo	<i>FC, Sen, SGCN</i>	LR	Regulate take, habitat with small forest openings, management for green belts, woodlots	Loss, fragmentation, and degradation of habitats from clearing for urban development, improper grazing practices, flood control, schemes to eradicate exotic vegetation
Mexican Spotted Owl ^e	<i>FT, Sen, SGCN</i>	LR, PJ-PS, PP	Habitat with small forest openings, regulate take, restrict disturbance of species and habitat	Loss of preferred mature and old growth forest habitat from timber harvesting and other cutting, altered fire regimes, stand-replacing fires
Burrowing Owl	<i>SOC, SGCN</i>	SGS, LR, PJ-PS	Restrict disturbance of habitat, habitat with undisturbed/undeveloped areas, mitigation by artificial nest structures and green belts, controlled (as opposed to uncontrolled) livestock grazing	Loss or alteration of grassland habitat from agricultural conversion or urbanization, elimination of burrowing rodents such as prairie dogs, improper grazing practices, burning, mowing, illegal shooting

Species	Legal Status^a	GAP Vegetation^b	Beneficial Management^c	Adverse Management^d
Black Swift ^e	<i>Sen, SGCN</i>	PJ-PS, PP	Aquatic habitat: wetlands, marshes	Disturbance at nesting caves
Southwestern Willow Flycatcher ^e	<i>FE, SE, SGCN</i>	LR	Thickets of riparian shrubs and small trees within 100m of surface water that is present (at minimum) May-September	Loss, fragmentation, or alteration of riparian habitat from water manipulation, urbanization, improper grazing practices, fire, vegetation eradication programs, negative impacts from recreation and research, demography of fragmented populations
Loggerhead Shrike	<i>Sen, SGCN</i>	SGS, LR, PJ-PS	Large habitat patch size, ecotones, prescribed fire, timber stand management, vegetate stream/ditch banks, coarse woody debris (downed logs), small forest openings, management for green belts, woodlots	Significant rangewide declines potentially linked to habitat loss/degradation from changing agricultural practices, brush control programs or other land use changes, pesticide contamination, collision with vehicles
Gray Vireo	<i>ST, SGCN</i>	PJ-PS	Small forest openings, ecotones, large habitat patch size, uneven age woodlands	Loss or alteration of quality juniper-grassland habitat from clearing, burning, and improper grazing practices, cowbird parasitism
Baird's Sparrow	<i>SOC, ST, SGCN</i>	SGS	Protection of passage and winter habitat (native prairie, grasslands)	Loss or degradation of native grassland habitat from improper grazing practices, shrub encroachment, land development, and oil and gas development
Small-footed Myotis	<i>Sen</i>	SGS, LR, PJ-PS, PP	Restrict disturbance of species	Livestock grazing in riparian zones, even-age forest management, pesticides and organic chemicals, general insecticides, general herbicides
Fringed Myotis	<i>Sen</i>	SGS, LR, PJ-PS, PP	Restrict disturbance of species and habitat, habitat in undisturbed/undeveloped areas, snags (large trees remaining to die in place)	Livestock grazing in riparian zones, even-age forest management, pesticides and organic chemicals
Long-legged Myotis	<i>Sen</i>	SGS, LR, PJ-PS, PP	Restrict disturbance of species, snags (large trees remaining to die in place), caves and abandoned mines	Livestock grazing in riparian zones, even-age forest management, pesticides and organic chemicals, general insecticides, general herbicides
Yuma Myotis	<i>Sen</i>	SGS, LR, PJ-PS, PP	Restrict disturbance of species	Livestock grazing in riparian zones, even-age forest management, pesticides and organic chemicals
Townsend's Big-eared Bat	<i>SOC, Sen</i>	SGS, LR, PJ-PS, PP	Restrict disturbance of species and habitat	Pesticides and organic chemicals, general insecticides, general herbicides
Yellow-bellied Marmot	<i>Sen</i>	PJ-PS, PP	Rock pile habitats, old growth forest, ecotones, large habitat patch size, controlled (as opposed to uncontrolled) livestock grazing	Chemical animal damage control (sodium cyanide M-44, zinc phosphide grain bait above or below ground), general herbicides

Species	Legal Status^a	GAP Vegetation^b	Beneficial Management^c	Adverse Management^d
Gunnison's Prairie Dog	<i>Sen</i> , <i>SGCN</i>	SGS, PJ-PS, PP	Restrict disturbance of species, regulate take	Sylvatic plague, unregulated taking, habitat loss/fragmentation
Heather Vole	<i>Sen</i>	PP	Regulate take, habitat with undisturbed/undeveloped areas	Chemical animal damage control (zinc phosphide grain bait above or below ground)
Red Fox	<i>Sen</i>	SGS, LR, PJ-PS, PP	Regulate take, allow movement to available habitat, wildlife food etc. plots	Chemical animal damage control (sodium cyanide M-44), non-chemical animal damage control (leghold traps, snares)
Ringtail	<i>Sen</i>	SGS, LR, PJ-PS, PP	Regulate take	Chemical animal damage control (sodium cyanide M-44), non-chemical animal damage control (leghold traps)
American Marten ^e	<i>ST</i> , <i>SGCN</i>	PP	Regulate take, allow movement to available habitat, restrict disturbance of species and habitat; habitat with undisturbed/undeveloped areas, snags (large trees remaining to die in place), coarse woody debris (downed logs), talus slopes, small forest openings, old growth vegetation, fire exclusion	Timber overharvest, forest habitat loss/conversion, wildfire
Western Spotted Skunk	<i>Sen</i>	SGS, LR, PJ-PS, PP	Protection of underground burrow/den habitats	Chemical animal damage control (sodium cyanide M-44)

^a **Legal Status codes** FE= Endangered under Federal Endangered Species Act (ESA); FT= Threatened under ESA; SOC= Federal Species of Concern; SE= Endangered under NM Wildlife Conservation Act (NMWCA); ST= Threatened under NMWCA; Sen= NM sensitive taxa (informal); SGCN= Species of Greatest Conservation Need as identified within the Comprehensive Wildlife Conservation Strategy for New Mexico (2006).

^b **GAP Vegetation Codes** (standard terms as established by US Geological Survey Biological Resources Division); SGS= short grass steppe; LR= lowland riparian; PJ-PS= piñon/juniper plus juniper savanna; PP= ponderosa pine.

^c Beneficial management practices are based upon information within BISON-M, searched October 2007.

^d Adverse Management practices are based upon the Comprehensive Wildlife Conservation Strategy for NM for all SGCN; practices all other taxa are based upon BISON-M search results.

^e These taxa may not be known to occur within the primary Galisteo Basin planning area. They are included here because potential habitat (occupied or unoccupied) exists, and species may occur within "buffer areas" that would be outside of, but potentially affected by, management actions for the primary planning area (e.g., forest thinning treatments for fuel reduction to protect adjacent properties).

APPENDIX J: RECOMMENDED CONSERVATION RESTORATION PRIORITIES

Location	Conservation task	Priority	Timeline	Key Actors	Observations
Central Bowl	Keep gaps in volcanic dikes open: Galisteo Creek gap, El Puertacito, Comanche Gap	2	2008-2010	Ranches, SF County, SFCT	SF County to include language in land use ordinance and/or SFCT and ranches to enter in CEs
	Manage highway fencing for pronghorn with NM DOT; facilitate wildlife crossings	3	2008-2010	NM DOT; ranches	
	Maintain bosque cover in/around Galisteo	1	2008-2009	EWI; landowners	Scheduled by EWI and landowners and NM DOT
	Maintain scenic quality of Cerro Pelon and its flanks and surrounding grasslands	2	2008-2010	Cerro Pelon Ranch, SFCT	
	Maintain scenic quality of Petroglyph Hill and its flanks and surrounding grasslands and ridges	2	2008-2010	SF County, GBP-CSO, EWI	Scheduled by SF County Open Space
	Minimize outdoor lighting (e.g. on movie set)	3	2008-2010	Cerro Pelon Ranch, SFCT, SF County	
	(Demo) Conservation (buffer) zoning, etc. needed along Galisteo Creek corridor	1	2008-2009	EWI; SF County; landowners	Under investigation by SF County
	Maintain viewshed from Clark Hill	3	2008-2010	NM DOT; Zorro Ranch	
	Maintain viewshed from Lamy Hill	2	2008-2010	NM DOT; SF County	
	Maintain scenic quality of ridges around Lamy	3	2008-2010	SF County	
	All major archaeological sites	1	2008-2010	BLM, SHPO, Arch Cons.	Under investigation by BLM and GBASPA
Headwaters and Forest Lands	Culverts and crossings in I-25 between headwaters and Glorieta Mesa	3	2008-ongoing	NM DOT, NM Game & Fish	
	Enforcement of development code needed	3	2008-ongoing	SF County	
	Enforcement of roadless character of forest	3	2008-ongoing	USFS	Under planning by USFS
Glorieta Mesa/Cerro Blanco	Conservation of archaeological sites	2	2008-ongoing	BLM, SHPO, Arch Cons., USFS, Ranches	Under investigation by BLM

Location	Conservation task	Priority	Timeline	Key Actors	Observations
Glorieta Mesa/Cerro Blanco (cont.)	Conservation of land on Glorieta Mesa and controlling development on landscape edges	3	2008-ongoing	SF County; landowners, SFCT	
	Conservation of open lands and stream bottom areas in Canoñcito	1	2008-ongoing	EWI, SFCT, SF County	
	Conservation of scenic values of escarpments and forest edges	2	2008-ongoing	SF County; landowners, SFCT	
	General landscape contiguity and connections with the Central Bowl	2	2008-ongoing	SF County; landowners, SFCT	
Northern Grasslands	Keep an open space corridor between Arroyo Hondo, Sunlit Hills, Eldorado and Rancho Viejo to allow wildlife to migrate from mountains to the open plains the SW	3	2008-ongoing	SFCT, SF County, landowners	
	Set fences to allow pronghorn migration	3	2008-ongoing	landowners, NM Game & Fish	
	Conservation of groundwater reserves to prevent downstream drying of springs and streams	3	2008-ongoing	OSE, SF County, landowners	Under scrutiny by GBWA
Ortiz Mountains	Management of development	3	2008-ongoing	SF County, landowners, SFCT	
	Conservation of scenic values of escarpments and forest edges	3	2008-ongoing	SF County, landowners, SFCT	
Rio Grande Delta	Galisteo Creek floodplain, wetlands and tributaries	1	2008-2010	EWI, landowners, SDT, ACE,	
	La Bajada viewshed, geology and water resources	3	2008-ongoing	SF County, SDT, landowners, SFCT, OSE	

Location	Conservation task	Priority	Timeline	Key Actors	Observations
Rio Grande Delta (cont.)	Connectivity across I-25 for wildlife to Rio Grande and Jemez Mnts.	3	2008-ongoing	NM DOT, SDT	Under investigation by SDT
Turquoise Trail	San Marcos Arroyo and wetlands and Galisteo Creek: need buffer zones	2	2008-2010	Arch Cons. Landowners, SFCT	Under investigation by EWI
	Cerrillos Hills area (to be protected against future mining)	2	2008-2010	SF County, BLM, State Parks	
	Madrid Historic Mining District	2	2008-2012	SF County, AMLB	Under investigation by Abandoned Mine Lands Bureau
Central Bowl (Demo)	Wetland restoration and thinning from Vista Clara to Tingle Ranch	1	2009-2015	landowners, ranches, EWI, State Forestry	Being discussed with Cerro Pelon Ranch
	Shoring up of old dam on Cerro Pelon Ranch	3	2015-2025	Cerro Pelon Ranch, NM DOT, NRCS, State Dam Bureau	Being discussed with Cerro Pelon Ranch
	San Marcos Arroyo and wetlands	2	2008-2010	EWI, Arch Cons., landowners	Scheduled and funded by FWS, NMED and others
	Erosion control on GBP	2	2008-ongoing	EWI, CC, GBP-CSO	Projects being implemented
	Erosion control in Arroyo Chorro drainage	2	2009-ongoing	landowners, EWI	
	Erosion control and water harvesting between CR42 and Galisteo Creek: arroyos and alluvial fans	2	2009-ongoing	landowners, EWI	
Headwaters & Forest Lands	Forest restoration to prevent wildfire and erosion	4	2015-ongoing	USFS, landowners	Forest Service NEPA process stalled
(Demo)	Wetlands, springs, streambanks, arroyos and streambottoms in the Glorieta-Cañoncito reach of Galisteo Creek (comprehensive multi-year program)	1	2010-ongoing	State Forestry, EWI, landowners, NM DOT, Highlands Univ.	Being discussed by EWI and State Forestry

Location	Conservation task	Priority	Timeline	Key Actors	Observations
Glorieta Mesa/Cerro Blanco	Wildfire management	4	2012-ongoing	USFS, State Forestry, landowners	Forest Service NEPA process stalled
	Erosion control on Glorieta Mesa; esp. along roads and ORV tracks and springs/arroyos and floodplain areas	2	2010-ongoing	EWI, landowners	
	Wildlife crossings along Hwy 285	3	2009-ongoing	NM DOT, ranches	
	Erosion control on Arch sites	2	2008-ongoing	BLM, EWI, arch cons. Ranches	
Northern Grasslands	Erosion control in Upper San Marcos drainage	2	2010-ongoing	EWI, SF County, landowners	
Ortiz Mountains	Erosion control in arroyos and maintaining arroyo connections with surrounding landscape	2	2010-ongoing	EWI, SF County, landowners	
Rio Grande Delta	Wildlife connectivity across I-25	3	2009-ongoing	NM DOT, SDT	Being considered by SDT
Turquoise Trail	San Marcos Wetlands - Cerrillos Hills springs	1	2008-2012	EWI, Arch Cons., landowners, Santa Fe County, State Parks,	Being planned and implemented by EWI and SF County
	Erosion control on Madrid mining sites and arroyos	2	2010-ongoing	NM AMLB, EWI, Santa Fe County	Under consideration with AMLB

APPENDIX K: SIGNIFICANT CONSERVATION VALUE (SCV) MODEL MAPS

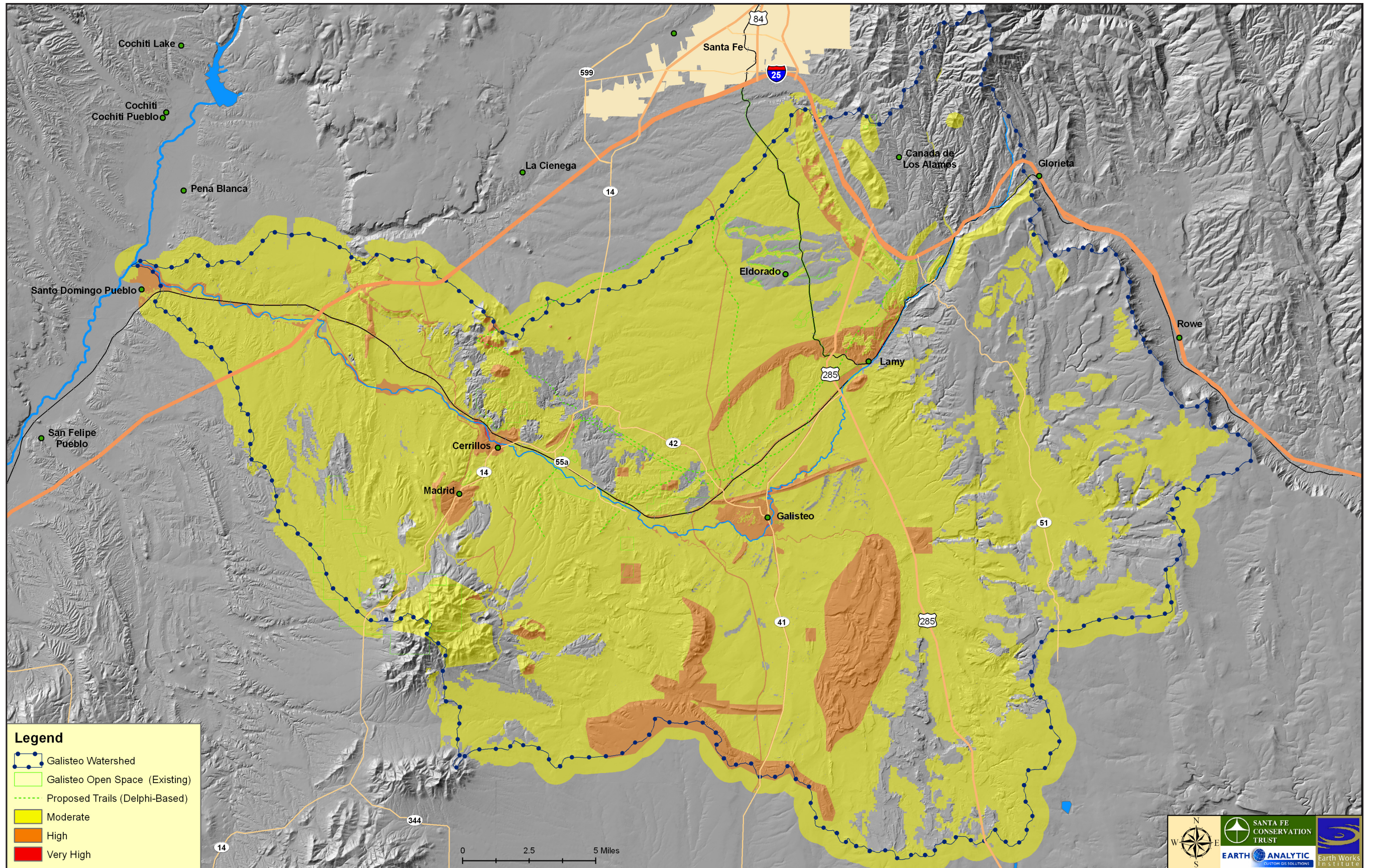

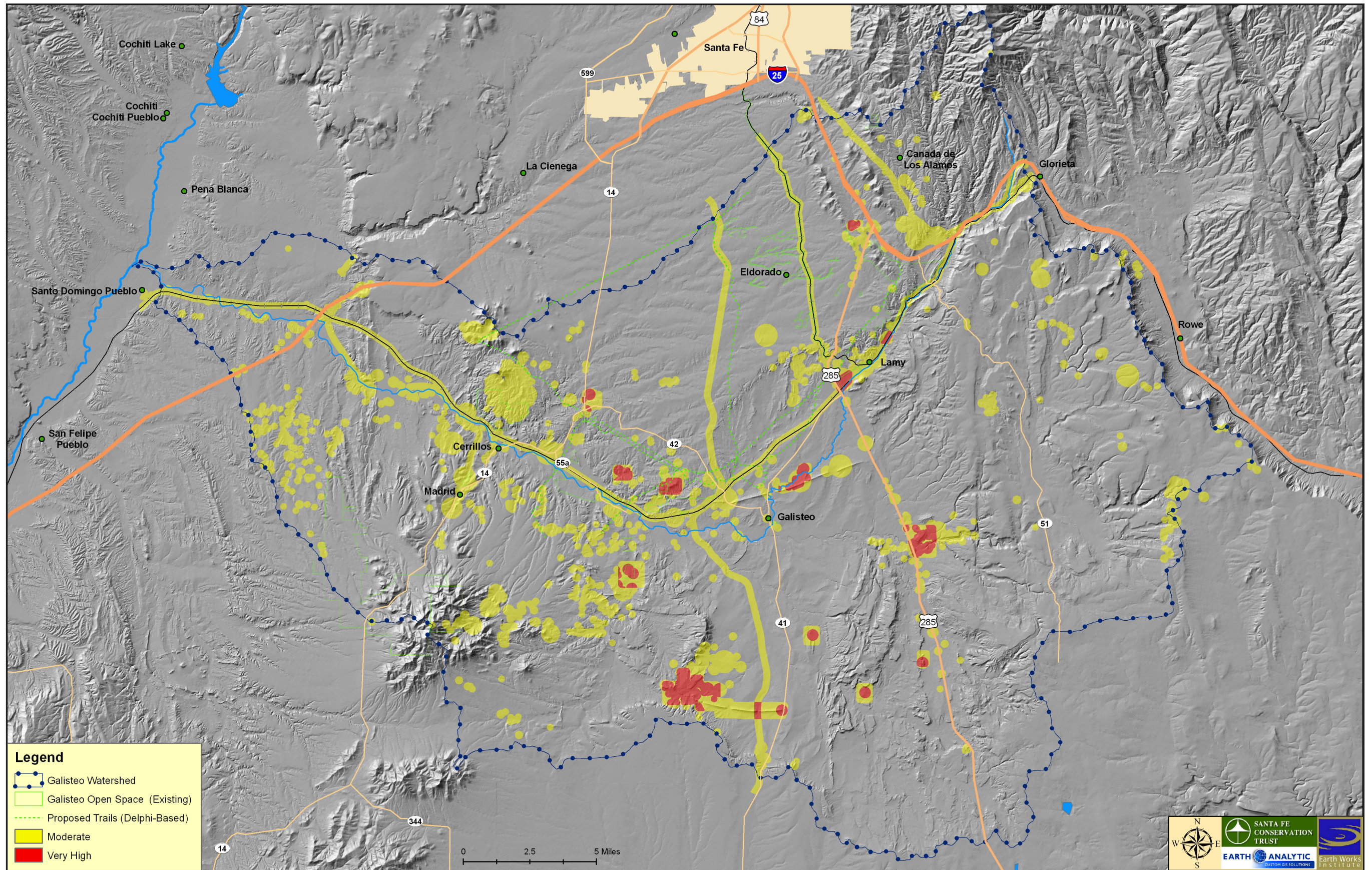

Legend

- Galisteo Watershed
- Galisteo Open Space (Existing)
- Proposed Trails (Delphi-Based)
- Moderate
- Very High

SANTA FE CONSERVATION TRUST
EARTH ANALYTIC
Earth Works Institute

